

CORROLINE

PTFE Lined Hose for the Chemical Industry



- CHEMICAL RESISTANT
- SELF-CLEANING
- FLEXIBLE
- KINK RESISTANT

CONTENTS

	Page
Front Cover	1
Contents	2
PTFE - The Optimum Choice for Hose Linings	3
Corroline Hose Description	4
Comparison with Competitors Hose	5
Corroline Specifications and Properties	6
Aflex Hose and Corroline	7
How to Order Corroline Hose Assemblies	8
Part Numbers for Corroline Hose Assemblies	9
HOSE	
- Corroline Hose Liners	10
- Corroline Hose Braids & Rubber Cover	11
- Corroline External Protection Options	12
FLANGES	
- Corroline Non-Lined Swivel Flange Fittings	13
- Corroline Integral PTFE Lined Swivel Flange Fittings and Step-Up Adaptors	14
CAM & GROOVE (CAM LOCK)	
- Corroline Female Cam & Groove Fittings, PTFE Lined and Non-Lined	15
- Corroline Male Cam & Groove Fittings PTFE Lined & Non-Lined and PTFE Lined Cam Male-to-Flange Adaptors	16
SANITARY (TRICLOVER)	
- Corroline Sanitary and Mini-Sanitary Triclamp (Triclover) Fittings	17
- Corroline 90° Elbow Sanitary Triclamp (Triclover) Fittings	18
DIN11851	
- Corroline DIN11851 Female Fittings, PTFE Lined and Non-Lined	19
JIC	
- Corroline 37° JIC Female Fittings and NPT Male & Female Unions	20
TUBE FITTING	
- Corroline Tube Adaptor (Grooved Standpipe) Fitting	21
NPT, BSPT & BSPP THREADED	
- Corroline NPT and BSPT Fixed Male Fittings and NPT Fixed Female Fittings	22
- Corroline 60° BSP Cone Seat Female Union Fittings and BSP Flat Seat Lug Nut Female Fittings	23
DIP PIPES	
- Corroline PTFE Dip Pipes	24
Corroline Standard & Pharamatag Labelling & Colour Coding systems	25
Corroline Hose: Special Usage Conditions	26
Quality Assurance, Certification and Approvals	27
Corroline Hose Configuration & Length Calculation	
- for Bend Radius	28
- for Abrasion & Torque	29
- for Length Calculation	30
Conditions of Sale	31

PTFE – THE OPTIMUM CHOICE FOR HOSE LININGS

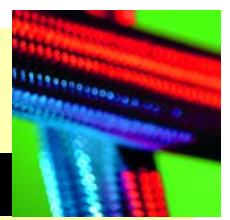

PTFE, or Polytetrafluoroethylene, comprises long-chain molecules of carbon atoms, each linked to two fluorine atoms.

The fluorine atoms provide a helical spiral which surrounds the carbon chain and protects it.

It is this structure which creates the unique properties for which PTFE is well-known.

EXCELLENT CHEMICAL RESISTANCE

PTFE is renowned as the most chemically resistant material known. Only a very few, very unusual substances and conditions can affect it, like fluorine gas at high temperature and pressure and liquid, boiling sodium metal.

PTFE lined hoses can therefore be used for a wider variety of chemicals than any other hose type, making it the ideal choice for very corrosive chemical applications and multi-product applications.

NON-STICK SURFACE

The use of PTFE as a surface for cookware products has demonstrated to the world how easily cleanable PTFE surfaces are.

This means that PTFE lined hoses can be purged 100% clean more quickly, easily and reliably than any other type of hose.

EXCELLENT TEMPERATURE RANGE

The cookware application also demonstrates another of PTFE's many attributes – temperature resistance. PTFE itself can be used as a hose liner at temperatures from -150°C up to $+260^{\circ}\text{C}$, dependent upon the hose design and the application conditions.

This is the widest temperature range of any rubber or plastic hose lining material.

HOSE DESIGN

The only issue with PTFE as a hose lining material is the best way it can be integrated in to the hose design. This is where Aflex Hose have a proven record of success over the last 30 years.

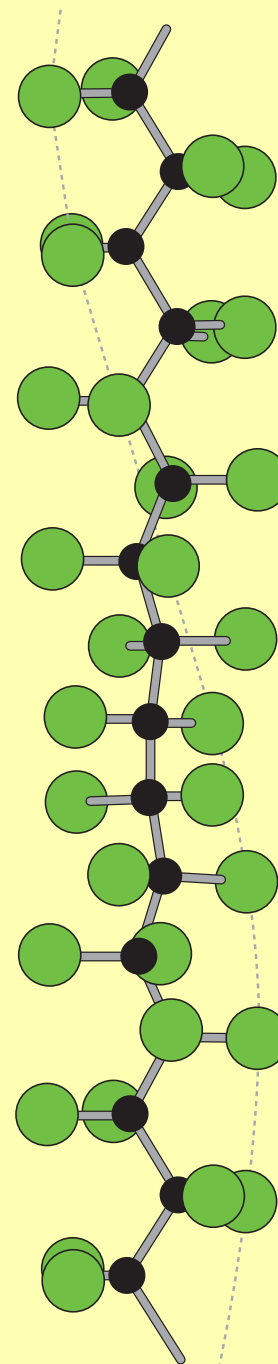

Section from a PTFE Molecule, 16 Angstrom Units long



Fluorine Atom



Carbon Atom

CORROLINE HOSE DESCRIPTION

INTRODUCTION

Corroline hose was designed and developed to provide customers with a universal chemical hose product which combined all the requirements they had requested for chemical plant applications, particularly the need for improved flexibility.

Corroline hose not only supersedes but also improves upon the wide variety of alternative Chemical Hose products currently available.

CONSTRUCTION

Corroline is built around a patented PTFE hose liner design, which has a slightly rippled smooth bore inside, but convoluted outside to generate excellent flexibility combined with "hoop strength".

A stainless helical wire is wound in to the external convolutions, which adds to the kink resistance, crush resistance and the resistance of the hose to both pressure and vacuum.

This reinforced PTFE Liner construction is strong enough to withstand full vacuum and kinking without the need for either internal convolutions or the need to bond the liner to an outer cover, making it an ideal hose liner design, and a significant improvement upon standard products currently available.

The PTFE liner is then further reinforced with an outer braid, either a Stainless Steel wire braid (SS Grade) or a Polypropylene braid (PB Grade) to provide two braided hose grades.

The most popular grade (RC Grade) includes an outer cover of abrasion resistant, black antistatic EPDM rubber which is extruded on to a SS braided liner, with a super-smooth surface finish to aid external cleaning. A yellow, "CORROLINE" stripe is printed on to the cover. Other texts and coloured stripes are also available to special order.

CORROLINE HOSE - THE BEST FLEXIBLE HOSE FOR CHEMICAL PLANT APPLICATIONS

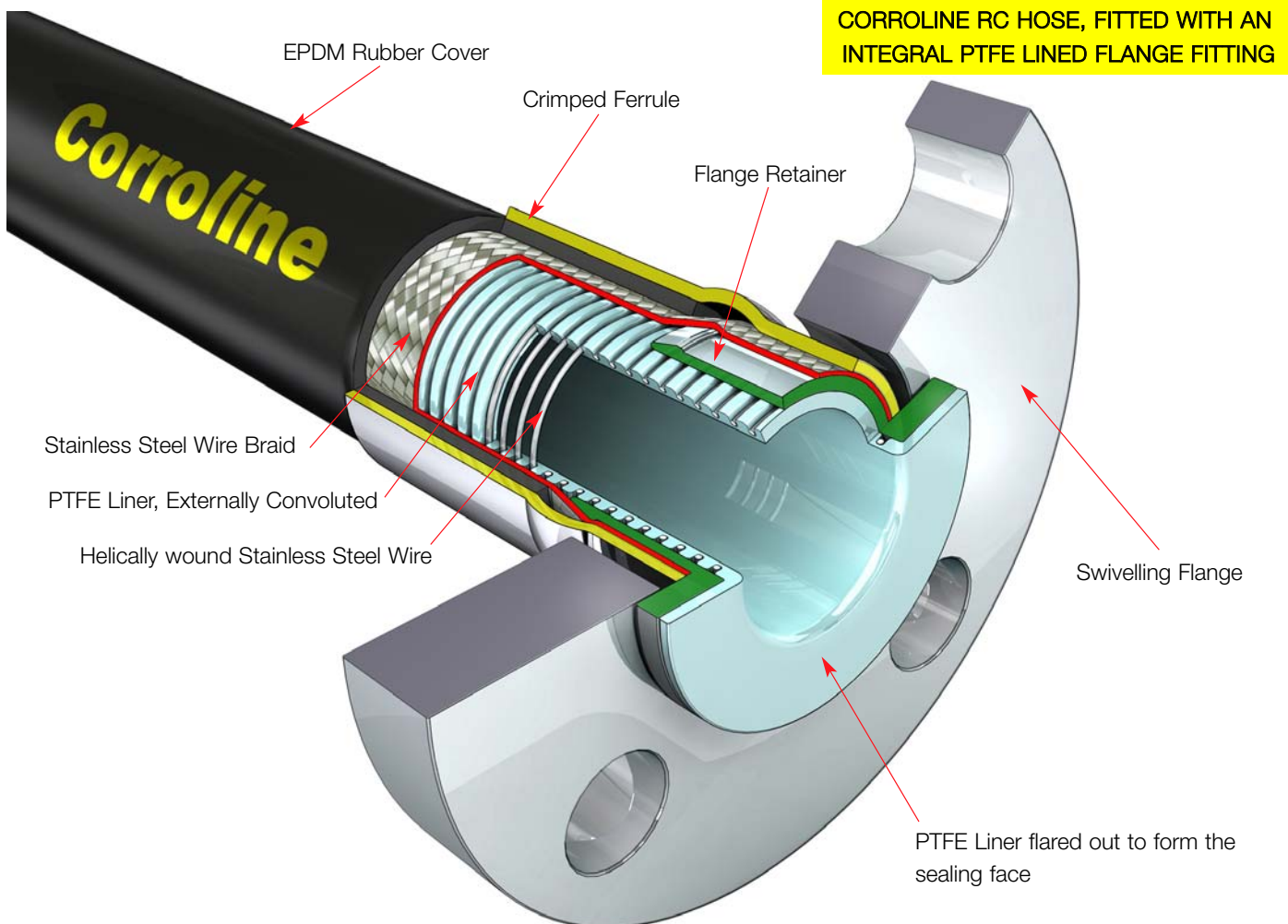

COMPARISON WITH COMPETITORS HOSE

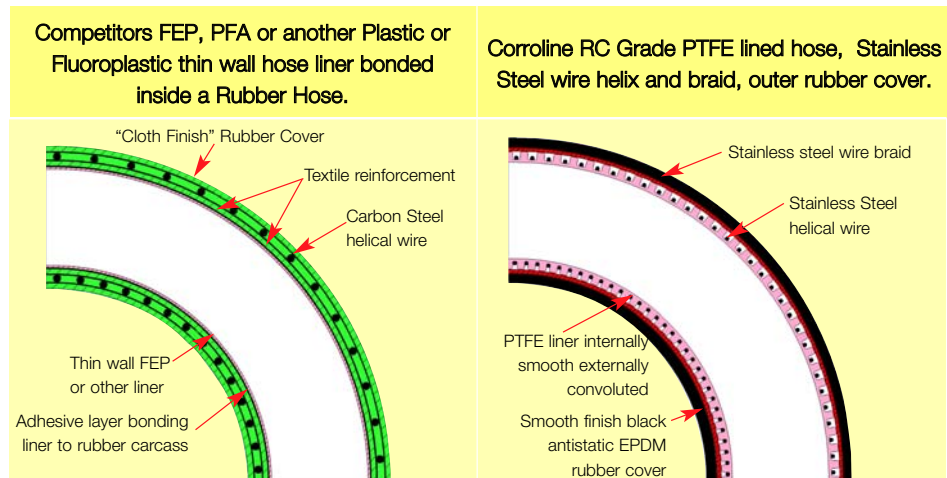
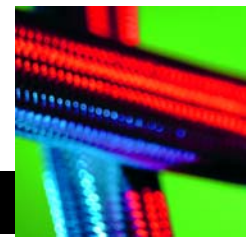

Bore Profile	Smoothbore, rippled round bends - Good flow rate - Easy clean	✓	Smoothbore, slightly rippled - Good flow rate - Easy clean	✓
Liner Material	FEP or another Fluoroplastic liner, Good but not as good as PTFE	✗	PTFE Liner -Best for chemical resistance and temperature resistance	✓
	XLPE or UHMWPE - Fair chemical resistance	✗		
Process Fluid Contamination Risk	High Risk - adhesive layer can leach in to contaminate the process fluid through pinholes in the thin wall liner, caused by static discharge, flex induced porosity, hose kinking etc.	✗	No Risk - no adhesive layer - no non-FDA approved materials present in the hose construction	✓
Flexibility	Fair to Poor - Very stiff, with a large minimum bend radius	✗	Good - More flexible, reduced minimum bend radius	✓
*Flex Life ("Rolling U" Test)	Poor, typically from 50 to 10,000 cycles to failure	✗	Excellent, 1,000,000+ cycles without failure	✓
Kink Resistance	Fair	✗	Good	✓
Helical Wire	Carbon Steel (can corrode)	✗	304 Stainless Steel	✓
Cut Through or Puncture Resistance	Fair (Textile braid protection)	✗	Good (Stainless Steel Wire Braid Protection)	✓
Antistatic Liner Quality To FDA Requirements (<2.5% High Purity Black)	Often more than 2.5% Black, often unevenly dispersed, leading to carbon agglomerates which contaminate Process Fluid	✗	Always less than 2.5% Black, very evenly dispersed and guaranteed agglomerate-free. "Leachable and Extractable" testing yields zero carbon.	✓

*The "Rolling U" test is shown on the Aflex Hose website "Aflex News" → "Bioflex and Corroflon compared with Competitor's Products".

CORROLINE SPECIFICATIONS & PROPERTIES

SPECIFICATIONS FOR CORROLINE HOSE GRADES

Nominal Hose Size ALL GRADES		Actual Bore Size ALL GRADES		Outside Diameter						Maximum Working Pressure				Minimum Bend Radius ALL GRADES		*Max Cont. Length ALL GRADES	
in mm		in mm		SS GRADE		PB GRADE		RC GRADE		SS & RC GRADE		PB GRADE		in mm		Ft Mtrs	
1/2	13	0.530	13.5	0.685	17.4	0.785	19.9	0.842	21.4	700	48	350	24	2 ³ / ₈	60	60	18
3/4	20	0.770	19.8	0.950	24.1	1.065	27.0	1.110	28.1	625	43	320	22	2 ¹ / ₂	65	60	18
1	25	1.030	26.1	1.250	31.7	1.455	36.9	1.445	36.7	600	41	300	20	4	100	60	18
1 ¹ / ₄	32	1.250	32.0	1.530	38.9	1.715	43.5	1.740	44.2	550	38	275	19	5 ¹ / ₄	135	60	18
1 ¹ / ₂	40	1.530	38.8	1.840	46.7	1.980	50.3	2.035	51.7	500	34	250	17	6 ³ / ₄	170	55	17
2	50	2.030	51.5	2.340	60.85	2.580	65.5	2.590	65.7	400	28	200	14	8 ¹ / ₄	210	42	13

*Sizes up to 1" are available in continuous lengths up to 120 ft (36 mtrs) to special order.

■ PRESSURE & TEMPERATURE LIMITATIONS

Internal Temperature Range Maximum Working Pressure (MWP) Limits

SS Grade -70°C to +260°C/-94°F to +500°F } As listed above up to 130°C/266°F, then reduce the MWP by 1% for
RC Grade -40°C to +140°C/-40°F to +284°F } every 1°C/1.8°F above 130°C/266°F.

PB Grade -30°C to +100°C/-22°F to +212°F - As listed above by to 80°C/175°F, then reduce by 50% from 80°C/175°F up to 100°C/212°F.

External Temperature Range - As for Internal above, except Maximum for RC Grade is 121°C/250°F and Maximum for PB Braid is 90°C/194°F.

Burst Pressures - The minimum burst pressures are equal to the maximum working pressures x 4.

■ VACUUM LIMITATIONS

SS and RC Grades - Useable at full vacuum up to 130°C/266°F internal temperature.

PB Grade - Useable at full vacuum up to 100°C/212°F.

■ FLOW RATES

More than 2x the flow rates for convoluted bore hose designs. Consult Aflex Hose for specific flow rate information.

■ GAS PERMEABILITY

More than 3x lower permeability than equivalent alternative PTFE lined hose designs, due to the heavy compression applied to the PTFE during processing, which reduces porosity.

■ "ROLLING U' TEST FLEX LIFE

More than 100x the flex life to failure compared with all other types of competing PTFE lined hose products.

■ FLEXIBILITY

Much less force to bend than any other smooth bore PTFE lined hose product.

■ KINK RESISTANCE

Much more resistant to kinking than any other smooth bore PTFE lined hose product.

AFLEX HOSE and CORROLINE

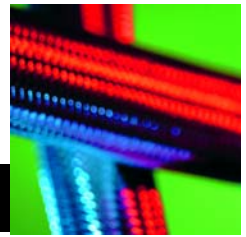

AFLEX HOSE LTD

Aflex Hose was established as a PTFE hose manufacturing company in 1973 and, since then, has led the world in inventing and developing all the major innovations in PTFE hose design for use in process fluids transfer applications. CORROLINE Hose is the latest addition to the Aflex Hose product range.

CORROLINE HOSE

Corroline hose has been developed specifically to provide a new smooth bore PTFE lined hose product range which combines excellent flexibility with excellent resistance to kinking and crushing.

Corroline hose is therefore well suited for use in Chemical Plants and other applications where the advantages of a smooth, clean PTFE liner are required together with the ability to withstand rough handling much better than alternative hose products.



Technically trained Aflex Hose sales staff are available to respond quickly and effectively to every kind of enquiry, and to advise the optimum hose solution for any application.

OTHER PRODUCTS

Aflex Hose also manufactures many more PTFE hose products for use in specific Process Fluid transfer applications. Corroflon, Bioflex, Pharmaline and Pharmalex are described in other brochures and information is also available on the Aflex Hose website

ROLLING 'U' TEST

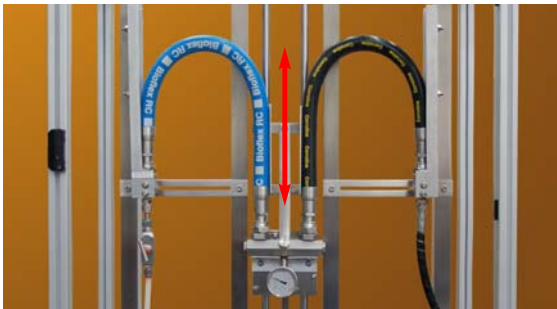

The "Rolling U" test is one of many tests carried out at Aflex Hose to prove hose suitability in application.

The "Rolling U" Test is designed to determine the flex life capabilities of hose products. Corroline has proved to have at least 100 times the flex life to failure when tested alongside the best of the competitors' PTFE lined hose products.

TOTAL MANUFACTURE

The primary reason for the success of the Aflex Hose range of products is that Aflex is the only PTFE hose company in the world to carry out all the hose design and manufacturing operations in house, from raw materials to finished products, at Aflex Hose plants in Yorkshire (UK) and Pennsylvania (USA).

- PTFE powder is extruded into tube and convoluted.
- Stainless steel wire is wound and braided onto the tube.
- Rubber extruders are used to apply external covers.
- End fittings are machined from bar stock on state of the art CNC lathes.
- And, finally, the hoses are assembled to individual customer requirements.

Because Aflex Hose perform all these operations in house, Aflex is able to achieve unbeatable levels of build quality, design excellence and economy of scale, which are unmatched by our competitors.



HOW TO ORDER CORROLINE HOSE ASSEMBLIES

CORROLINE HOSE ASSEMBLIES

Corroline hose is custom built into hose assemblies after the hose size and grade, length and end fittings have been selected. The specification and information contained in this brochure can be used to make these selections, but if there are any doubts concerning the hose usage limitations or performance capabilities, customers should request expert advice from Aflex Hose.

SELECTING THE HOSE GRADE

There are two types of PTFE hose liner tube available, natural GP grade and antistatic (black) AS grade, fully described on page 10
There are 3 types of cover available, as described on Page 11:

- Stainless Steel Wire Braid (SS Grade)
- Stainless Steel Wire and extruded Rubber Cover (RC Grade)
- Polypropylene Braid (PB Grade)

There are 3 options for further protection of the hose against externally applied mechanical damage, fully described on page 12:

- Double Rubber Cover end protection cuffs (DRC)
- Safeguard HDPE spiral-wrap for abrasion protection (SG)
- Helically wound, heavy gauge SS wire outer Protection Coil (PC)

SELECTING THE HOSE ASSEMBLY LENGTH

The lengths of Corroline hose assemblies are as specified by the customer and the length is measured from the sealing face at one end fitting to the same at the other end of the hose.

Length tolerances are normally +5% -0%.

Maximum lengths are given under Specifications on page 6

Minimum lengths can be calculated from the configuration data on pages 27 - 29.

SELECTING THE END FITTINGS

The range of standard end fittings and materials are given on pages 13 - 24

Flange fittings, Cam and Groove fittings and DIN 11851 Female fittings are available with or without integral PTFE lined and flared ends.

All other fittings are non-lined only.

STAINLESS STEEL END FITTING MATERIALS

Non-Lined Spigots - are all made from Grade 316L SS

PTFE Lined Spigots - are all made from Grade 316L or Grade 316C SS

Cam and Groove Female Fittings - are made from Grade 316C SS (Body) and 316L SS (Spigot)

Swivelling Nuts and Flanges - are all made from Grade 304 SS

Ferrules - most ferrules are made from Grade 304 SS, except some which are made from Grade 316L SS. Consult Aflex Hose if necessary.

The equivalent specification for the different Grades of Stainless Steel are listed below:

Specification Equivalents List

Grade	BS - British Standard	AISI - American Standard or C = Casting Grade	EN - European Norm
316L SS	BS 316 S11	AISI 316 L	EN 1.4404
316C SS	BS 316 C16	CF8M	EN 1.4408
304 SS	BS 304 S15	AISI 304	EN 1.4301

To special order, end fitting components can be made in non-standard grades of SS such as 1.4571, 1.4435, or other materials such as Hastelloy or Monel

HOW TO ORDER

The quantity, hose size, grade, length and fittings must be specified in full.

EITHER by a full, written description. The hose grade can be specified by the code initials e.g.. "Corroline AS, SS, SG" defines an antistatic PTFE lined hose with an SS wire braid which includes an outer Safeguard sleeve.

The quantity, length and fittings can then be written in - e.g. "4 off x 1" bore Corroline AS, SS, SG hose x 3.00 metres long. Both ends non-lined ANSI 150# S/S Flanges".

OR by Part Numbers, as defined on page 9 - e.g. 4 off Part No. 16-CLNAS-SS-SG-3.00m-12-12

Any special requirements relating to the hose construction, or information required on Tags, or Certificates, or special testing requirements, must be specified in full on the enquiry or purchase order.

CONDITIONS OF SALE

Corroline hose and hose assemblies are only supplied on the basis that the customer has read and accepted the Conditions of Sale as given on page 30.

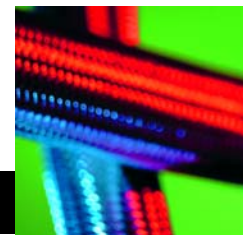

PART NUMBERS FOR CORROLINE HOSE ASSEMBLIES

Corroline Hose Assemblies are defined by an individual Part Number made up of 7 entries as follows:

1	Hose Size	Size Part No.	6 & 7	Assembled End Fitting Description *All Components in Stainless Steel	End Fitting Part No.
	1/2"	08		JIC Female	02
	3/4"	12		Fixed Male Pipe, NPT Thread	03
	1"	16		Fixed Female Pipe, NPT Thread	06
	1 1/4"	20		JIC-to-NPT Male Union	08
	1 1/2"	24		JIC-to-Female Male Union	08F
	2"	32		Straight Sanitary Tri Clamp, 50.5mm, 1.984" Diameter	
				22mm, 0.870" Exit Diameter (Standard)	10
				34.9mm, 1.370" Exit Diameter (Step-Up)	10/S
				Straight Mini Sanitary, 0.984" Diameter	
				0.370" Exit Diameter (Standard)	11
				0.620" Exit Diameter (Step-Up)	11/S
				DIN11851 Female Fitting	23
				*ANSI 150# Swivelling Flange, Non-Lined	12
				*ANSI 150# Swivelling Flange, PTFE Lined	12L
				Cam and Groove, Locking Arm Swivelling Female, Non-Lined	16
				Cam and Groove Locking Arm Swivelling Female PTFE Lined	16L
				Cam and Groove Male, Non-Lined	17
				Cam & Groove Male, PTFE Lined	17L
				DIN11851 Female, PTFE Lined	23L
				DIN11851 Female, Non-Lined	23

2	Hose Type	Type Part No.	
	Corroline GP (Natural PTFE Liner)	CLN	
	Corroline AS (Antistatic PTFE Liner)	CLNAS	

3	Braid & Cover	Part No.	
	Stainless Steel Braid	SS	
	Rubber Cover	RC	
	Polypropylene Braid	PB	

4	External Protection	Type Part No.	
	Double Rubber Cover	DRC	
	Safeguard HDPE Sleeve	SG	
	S/S Wire Protection Coil	PC	

5	Length	
	The overall hose length between the sealing faces at each end is given as the <u>Length Part No.</u> , either in decimal Metres followed by "m" or Inches followed by "in".	

*For flange only, Carbon Steel Zinc Plated, add "/ZP" or Epoxy coated add "/EC"

Notes: ELBOWS - Elbow Fittings for all types are indicated by adding "/90°" for 90° elbows, Non-Lined or "/90° L" for 90° elbows, PTFE Lined.

Example: a 3/4" bore Corroline Hose Assembly with an Antistatic PTFE Liner, SS Braid and Rubber Cover and an outer Safeguard sleeve.

End (1) - a 3/4" ANSI 150# Swivel Flange, PTFE Lined

End (2) - a Cam and Groove Swivelling Female, PTFE Lined

Length - 2.35 metres

Part No: 12-CLNAS-RC-SG-2.35m-12L-16L

1
2
3
4
5
6
7

CORROLINE HOSE - GP and AS PTFE LINERS

GP - GENERAL PURPOSE LINER

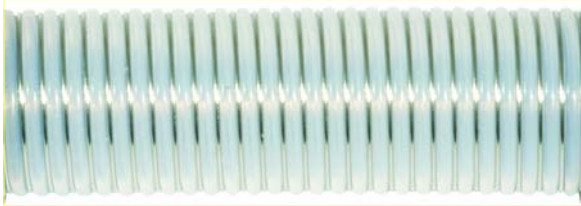

PURPOSE

Corroline GP is the 'General Purpose' grade, for use in all applications where fluids or gases are being conveyed which do not generate a risk of static charge development (see "AS").

MATERIALS & SPECIFICATIONS

Corroline GP is a virgin PTFE liner, manufactured from hose grade PTFE which conforms to the requirements of: FDA 21 CFR 177.1550

The helical reinforcement is High Tensile Grade 304L SS wire.

GP & AS GRADE APPROVALS

The full list of approvals and certifications are given on page 26.

Both Grades have also been tested for Leachables and Extractables in accordance with BPSA recommendations, with satisfactory results.

Copies of the Report are available from Aflex Hose.

AS - ANTI-STATIC PTFE LINER



PURPOSE

Corroline AS is an essential requirement in applications where there is the risk of an electrostatic charge build-up on the inside surface of the PTFE tube which may then discharge through the tube wall. Media passing through which create such a risk are fluids which have a Conductance of less than 10^{-8} S/m (Siemens per Metre), or 10^4 pS/m such as fuels, solvents, freons, some WFI (ultra-pure "Water for Injection") and non-polar organics which are being transferred at a medium to high flow velocity.

All twin or multi phase media, and any non-mixing media, such as powder in air, or water droplets in steam, in gases or in oil, also colloidal fluids constitute a particular hazard for static charge generation, and always require grade AS.

If in doubt, consult Aflex Hose.

MATERIALS & SPECIFICATIONS

Corroline AS is an anti-static PTFE liner manufactured from FDA approved PTFE, and less than 2.5% of "high purity" Carbon Black material to FDA requirement 21 CFR 178.3297 and European Commission Directive 2007/19/EC. The carbon is encapsulated by the PTFE, and in normal, non-abrasive applications will not come loose to contaminate any fluid passing through. This has been proved during Leachables and Extractables testing.

SPECIFICATIONS

When "AS" (Antistatic) grade hose is specified, then the hose supplied will be in accordance with the requirements of BS5958 Part 2, 1991 Clause 19.3, when tested in accordance with EN ISO 8031 Clause 3.1, which requires that the resistance between a plug inserted 25mm into the bore at the end of the hose assembly, and one of the metallic end fittings should be less than 10^8 ohms.

NOTE: When in service, at least one end fitting must be connected to earth, to permit dissipation of the static charge from the end fitting.

CORROLINE HOSE BRAIDS & RUBBER COVER

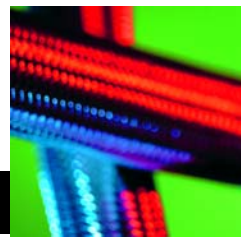

SS - STAINLESS STEEL BRAID

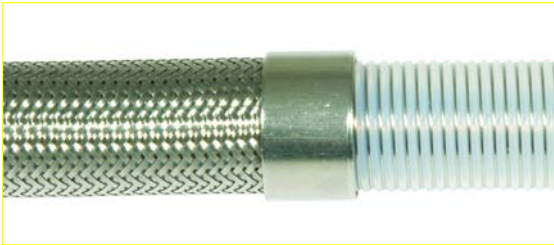

PURPOSE

Stainless Steel braided hose can be used in applications involving high temperatures and working pressures. High tensile AISI 304L stainless steel wire is used, to give maximum pressure resistance and external protection to the hose.

PB - POLYPROPYLENE BRAID

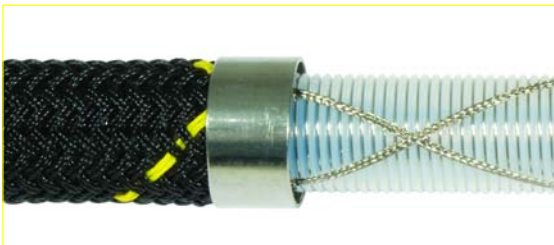

PURPOSE

Polypropylene braided hose is often preferred to SS in applications involving frequent handling and movement of the hose. PB braid is lighter in weight, and any broken strands will not cut the operator's hands. In addition, PB braid is not prone to "chloride stress corrosion", and has generally good chemical resistance.

To ensure *Electrical Continuity between end fittings, 2 strands of Monel wire earthing strips are criss-crossed on to the liner, underneath the Polypropylene Braid. These are folded back underneath the ferrule at both end fittings, to make an electrical contact.

NOTE: Prolonged exposure to sunlight eventually results in UV degradation of PB braid.

RC - RUBBER COVER



PURPOSE

RC Grade hose is the general purpose product, used in a wide variety of applications. A Black, Antistatic EPDM rubber is extruded over the SS braided product, to protect the SS braid with a tough, abrasion resistant rubber cover. The rubber cover hose has a smooth finish, to make it easy to wipe clean.

A yellow "CORROLINE" stripe is printed on to the cover. Other texts and coloured stripes are available to special order.

SPECIAL NOTE

ELECTRICAL CONTINUITY

Electrical continuity requires that the hose assembly supplied is electrically continuous, or conductive, between metal end fittings at each end of the hose. This can apply whether the hose is GP or AS grade.

The requirements for electrical continuity are specified in the German Document BRG132, and the Specification EN ISO 12115, tested to EN ISO 8031 Clause 3.7, which requires that for hose assemblies with a resistance between fittings of $\leq 10^2$ ohms, a letter "M" can be applied, or $\leq 10^6$ ohms, a letter "Ω" can be applied.

Corroline Hose Assemblies are all electrically continuous with a resistance of <20 ohms, and therefore meet the requirements of both "M" and "Ω", but are not stamped unless requested.

CORROLINE EXTERNAL PROTECTION OPTIONS

DOUBLE RUBBER COVER END PROTECTION - DRC 300

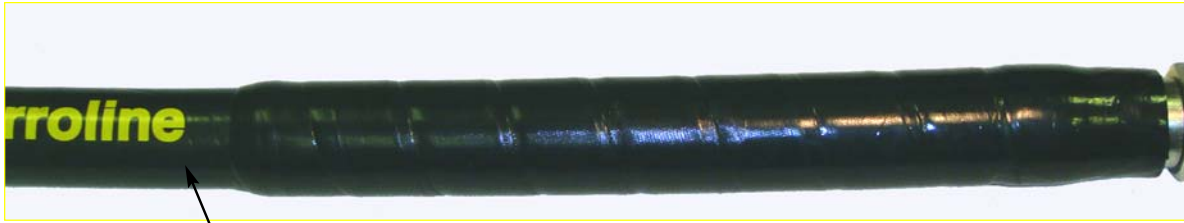

■ Purpose

In applications where the hose assembly will be flexed excessively at the end fitting, to prevent kinking of the hose in this area.

■ Design

A second layer of rubber is applied and vulcanised directly on to the hose and the end fitting ferrule, 12" (300mm) along the hose from the fitting.

■ Available for Grades SS and RC, not for Grade PB.

SAFEGARD HDPE SPIRAL WRAP PROTECTION - SG



■ Purpose

To protect the hose from excessive external abrasion and mechanical damage in rough applications.

■ Design

A lightweight black HDPE (High Density Poly Ethylene) 'Safeguard' strip is spirally wound along the hose and secured by crimping at each end.

■ Available for all Corroline Hose Grades.

■ Limitations

Temperature Range -40°F (-40°C) up to 212°F (100°C).

STAINLESS STEEL WIRE PROTECTION COIL - PC

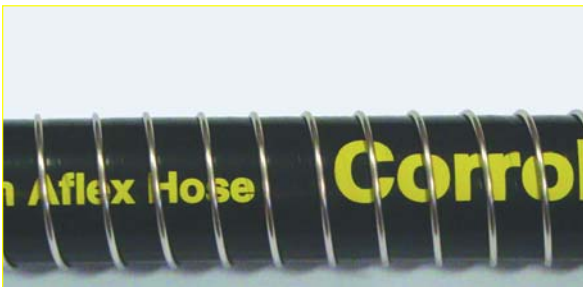

■ Purpose

To protect the hose from excessive external abrasion and mechanical damage in rough applications without the temperature limitations which apply to the Safeguard sleeve.

■ Design

A large diameter stainless steel wire is spirally wrapped on to the rubber cover, and welded to the ferrule at each end.

■ Available for all Corroline Hose Grades.

CORROLINE NON LINED SWIVEL FLANGE FITTINGS

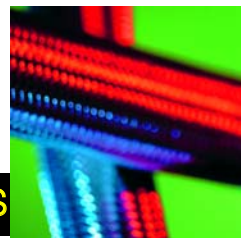

Flange Specification

- ANSI B16.5 (also ASME B16.5) Class 150# and 300#
- *DIN PN10/PN16/PN40
- JIS 10K
- Other Pressure Ratings and Flange Specifications are also available.

*DIN PN10, PN16 and PN40 Flanges all have the same dimensions, and so are fully interchangeable.

Pressure Ratings

- ANSI 150# = 230 psi (16 Bar), ANSI 300# = 460 psi (32 Bar).
- DN PN10 = 145 psi (10 Bar), DN PN16 = 230 psi (16 Bar). DN PN40 = 580psi (40 Bar)

End Fitting Materials

- Flanges in Grade 304 SS
- Flange Retainers in Grade 316L SS
- Ferrules, most in Grade 304 SS, some sizes in Grade 316L SS

Alternative Options for Flange Component only:

- Zinc Plated Carbon Steel
- Blue Epoxy Coated Carbon Steel

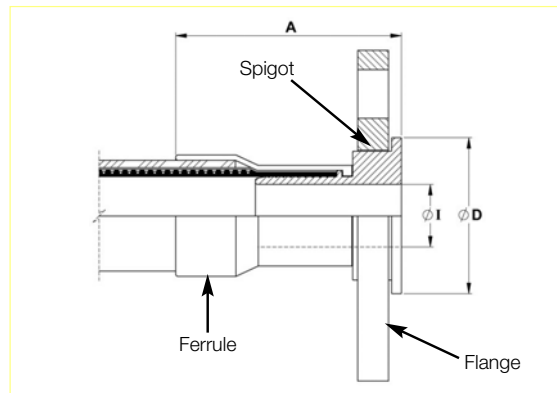

Nominal Hose Size		*Fitting Length A		Flared Diameter D				Fitting Inside Diameter I	
in	mm	in	mm	ASA150		**PN10/16/40		in	mm
1/2	13	2.79	71	1.38	35	1.77	45	3/8	9.53
3/4	20	3.15	80	1.69	43	2.28	58	5/8	15.88
1	25	3.27	83	2.00	50	2.68	68	3/4	20.24
1 1/4	32	3.90	100	2.50	63	3.00	78	1	26.20
1 1/2	40	4.25	108	2.88	73	3.47	88	1 1/4	31.75
2	50	4.25	107	3.63	92	4.00	102	1 3/4	44.45

*Fitting Lengths listed are for RC Grade Hose end fittings. SS and PB Grades end fittings are shorter in length.

CORROLINE INTEGRAL PTFE LINED FLANGE FITTINGS and "STEP-UP" DESIGN

Flange Specifications

- ANSI B16.5 (also ASME B16.5) Class 150# and 300#
- *DIN PN10/PN16 and PN40
- JIS 10K
- Other Pressure Ratings and Flange Specifications are also available.

*DIN PN10, PN16 and PN40 Flanges all have the same dimensions, and so are fully interchangeable.

Pressure Ratings For Flanges

- ANSI 150# = 230 psi (16 Bar), ANSI 300# = 460 psi (32 Bar)
- DN PN10 = 145 psi (10 Bar), DN PN16 = 230 psi (16 Bar)

End Fitting Materials

- Flanges in Grade 304 SS
- Flange Retainers in Grade 316L SS
- Ferrules, most in Grade 304 SS, some sizes in Grade 316L SS

Alternative options for Flange component only:

- Zinc Plated Carbon Steel
- Blue Epoxy Coated Carbon Steel.

90° Elbow Flange Fittings

90° Elbow Integral PTFE lined Flange Fittings are available for sizes 1", 1 1/2" and 2" - Consult Aflex Hose for details

INTEGRAL PTFE LINED SWIVEL FLANGE FITTINGS

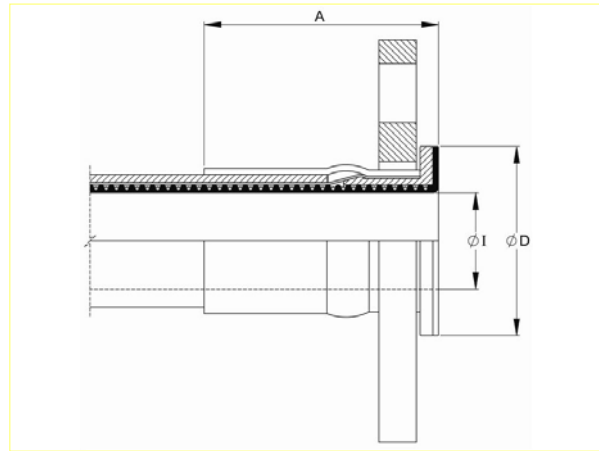
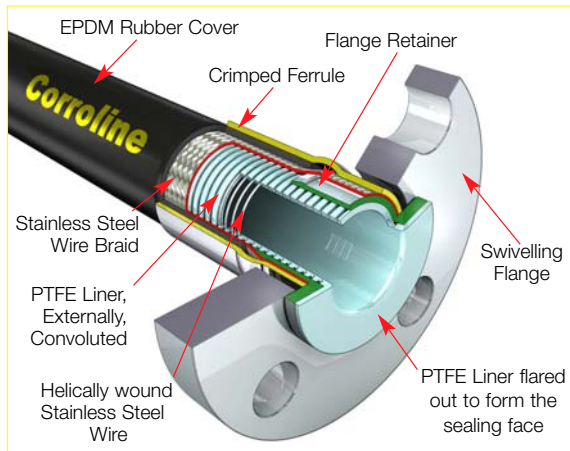

Nominal Hose Size		*Fitting Length A		Flared Diameter D				Fitting Inside Dia. and Hose Bore I		Recommended Bolt Tightening Torques	
				ANSI 150#		**DIN PN10/16/40					
in	mm	in	mm	in	mm	in	mm	in	mm	ft.lbs	mtr. kgs
1/2	13	1.440	37.0	1.25	32	1.25	32	1/2	12.7	8	1.10
3/4	20	1.440	37.0	1.690	43	1.97	50	3/4	19.0	8	1.10
1	25	1.625	40.5	2.00	50	2.50	63	1	25.4	10	1.40
1 1/4	32	1.625	40.5	2.500	63	3.00	78	1 1/4	32.0	12	1.70
1 1/2	40	1.875	47.0	2.875	73	3.47	88	1 1/2	38.0	15	2.10
2	50	1.940	48.5	3.625	92	4.00	102	2	50.8	25	3.50

*Fitting Lengths listed are for RC Grade Hose end fittings. SS and PB Grades end fittings are shorter in length.

**The listed Flare Diameters are not all full size, due to limitations on PTFE flare diameters.

"STEP-UP" PTFE LINED FLANGE FITTING DESIGN FOR CORROLINE HOSE

Because Corroline Hose has better flow rates than some larger bore sizes of Convolute PTFE hose, it represents a superior alternative when fitted with the larger size flanges in some applications.

It is, however, necessary to also "Step-Up" the PTFE-lined bore, to ensure a diameter match with the mating connector.

This is best achieved using a solid PTFE Adaptor Plate, as shown in the drawing.

Example: a 2" hose to 3" ANSI 150# PTFE Lined Flange Joint

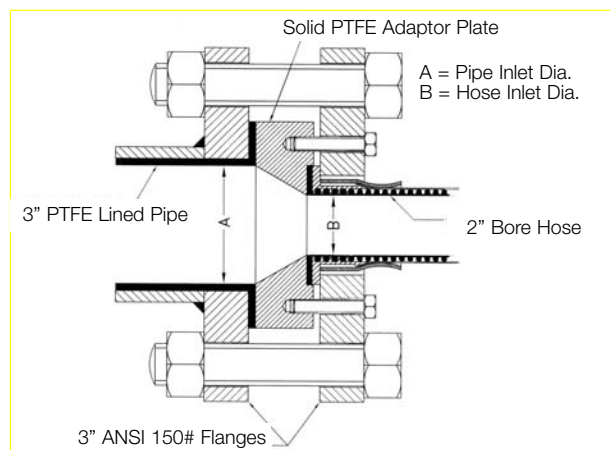

CORROLINE FEMALE CAM & GROOVE FITTINGS PTFE LINED and NON-LINED

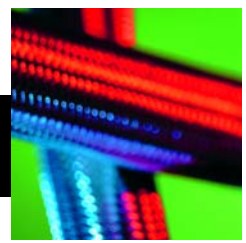

End Fitting Specification

- Generally in accordance with A-A-59326 (replaces MIL-C-27487) and EN14420-7:2004 (replaces DIN 2828), and all are fully interchangeable.

Temperature and Pressure Ratings

- All sizes up to 230 psi (16 Bar)
- Up to 212°F (100°C) Buna N Gasket or 400°F (200°C) FEP Gasket.

End Fitting Materials

- Spigot in Grade 316L SS
- Body in Grade 316C SS
- Ferrules, most in Grade 304 SS, some sizes in Grade 316L SS
- Standard Gasket is Buna N (Nitrile) Rubber.
- FEP encapsulated Silicone Rubber Gaskets also available.

90° Elbow Cam & Groove Fittings

- 90° Elbow Integral PTFE lined Cam & Groove Fittings are available for sizes 1", 1½" and 2". Consult Aflex Hose for details.

SWIVELLING, LOCKING ARM FEMALE CAM AND GROOVE FITTING - INTEGRAL PTFE LINED

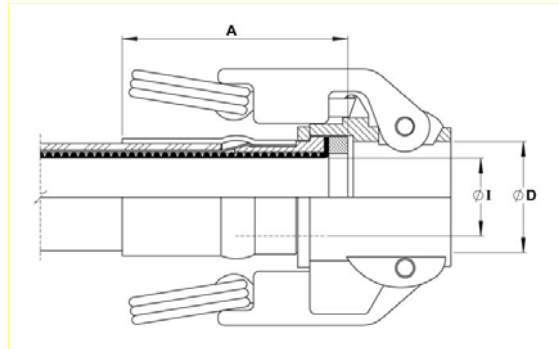

Nominal Hose Size		*Fitting Length A		Cam Sleeve Inside Diameter D		Fitting Inside Diameter I	
in	mm	in	mm	in	mm	in	mm
3/4	20	2.155	54.75	1.260	32.0	0.77	19.8
1	25	2.716	69.00	1.456	37.0	1.03	26.1
1½	40	2.612	66.35	2.126	54.0	1.53	38.8
2	50	2.966	75.35	2.520	64.0	2.03	51.5

*Fitting Lengths listed are for RC Grade Hose end fittings. SS and PB Grades end fittings are shorter in length.

SWIVELLING, LOCKING ARM FEMALE CAM AND GROOVE FITTINGS - NON LINED

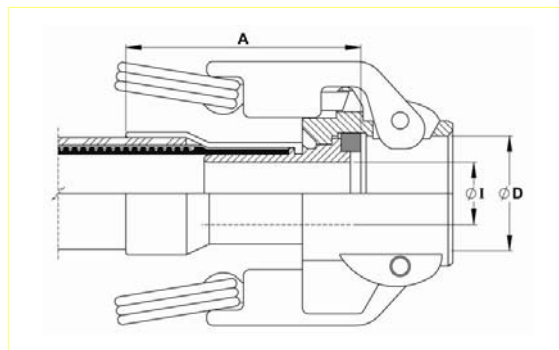

Nominal Hose Size		*Fitting Length A		Cam Sleeve Inside Diameter D		Fitting Inside Diameter I	
in	mm	in	mm	in	mm	in	mm
3/4	20	3.22	82.0	1.260	32	0.625	15.88
1	25	3.39	86.5	1.456	37	0.797	20.24
1½	40	3.97	101.0	2.126	54	1.25	31.75
2	50	4.09	104.0	2.520	64	1.75	44.45

*Fitting Lengths listed are for RC Grade Hose end fittings. SS and PB Grades end fittings are shorter in length.

CORROLINE MALE CAM & GROOVE FITTINGS, PTFE LINED & NON-LINED and LINED FLANGE ADAPTORS

PTFE LINED OR NON-LINED MALE CAM AND GROOVE FITTINGS

End Fitting Specification

- Generally in accordance with A-A-59326 (replaces MIL-C-27487) and EN14420-7:2004 (replaces DIN 2828), and all are fully interchangeable.

Temperature and Pressure Ratings

- Temperature determined by the type of gasket in the Female connecting component.
- Pressures up to 230 psi (16 Bar)

End Fitting Materials

- Fittings in Grade 316L SS
- Ferrules, most in Grade 304 SS, some sizes in Grade 316L SS
- Adaptor Flange Only in Grade 304 SS



NON-LINED CAM & GROOVE MALE

INTEGRAL PTFE LINED CAM & GROOVE MALE FITTING

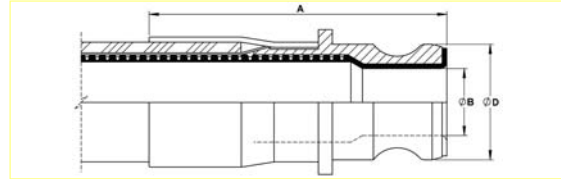

NON-LINED CAM & GROOVE MALE FITTING

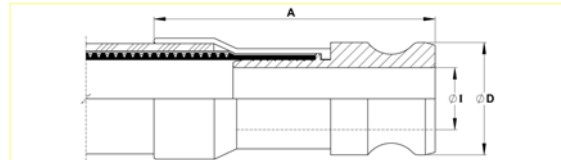

Nominal Hose Size		øD		*Fitting Length A		Non-Lined Inside Diameter I		Lined Inside Diameter B	
in	mm	in	mm	in	mm	in	mm	in	mm
3/4	20	1.260	32.0	3.50	89.0	0.625	15.88	0.72	18.2
1	25	1.456	37.0	3.97	101.0	0.797	20.24	0.77	19.6
1 1/2	40	2.106	53.5	4.88	124.0	1.25	31.75	1.26	32.1
2	50	2.480	63.0	5.47	139.0	1.75	44.45	1.59	40.5

*Fitting Lengths listed are for RC Grade Hose end fittings. SS and PB Grades end fittings are shorter in length.

PTFE LINED MALE CAM and GROOVE X FLANGE ADAPTORS

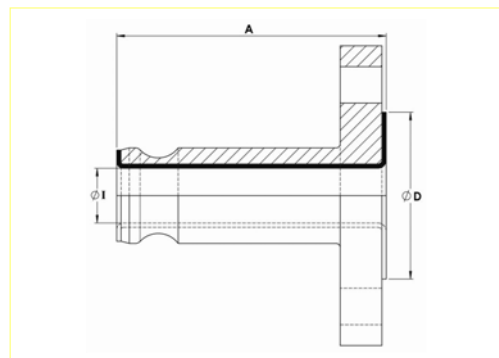

Cam Action Adaptor Size		Flange Size & Specification	øD		A		I	
in	mm		in	mm	in	mm	in	mm
1	25	1" ANSI 1507	2.00	50	4 1/8	105	0.84	21
1	25	DN25/PN16	2.58	64	4 1/8	105	0.84	21
1 1/2	40	1 1/2" ANSI 1507	2.87	73	4 3/8	118	1.35	34
1 1/2	40	DN40/PN16	3.47	88	4 3/8	118	1.35	34
2	50	2" ANSI 1507	3.63	92	4 3/8	118	1.69	43
2	50	DN50/PN16	3.63	102	4 3/8	118	1.69	43

Note: Other Flange Specifications and Pressure Ratings are also available. Non-Lined adaptors and Female Cam and Groove X Flange Adaptors are also available, to special order.

CORROLINE SANITARY & MINI SANITARY TRICLAMP (TRICLOVER) FITTINGS

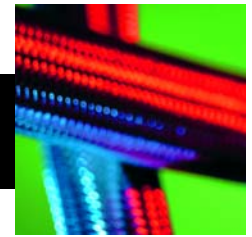

End Fitting Specification

- Generally in accordance with BS4825:Pt 3 and ASME BPE-a-2007, or DIN 32676 (The DN sizes)

Temperature and Pressure Ratings

For Standard Clamp and Standard (EPDM) Gasket

- Pressures up to 230 psi (16 Bar)
- Temperatures up to 250°F (120°C)
- Higher Pressures and Temperatures with Special Clamps and Gaskets.

Hygienic Fitting Design

The leading edge of the fitting tail is internally chamfered to ensure that no fluid entrapment can occur.

End Fitting Materials

- Fittings in AISI 316L = EN 1.4404 = BS 316 S11. Internal Bores all Electropolished to <math><15\mu\text{in Ra}</math> (<math><0.375\mu\text{mtr}</math>).
- Ferrules, most in Grade 304 SS, some sizes in Grade 316L SS.

Outlet Diameters (Inch pipe sizes only)

The outlet diameters as listed are in accordance with BS4825. The ASME specification, however, requires these diameters to be 0.005" (0.125mm) less in each case. An Outlet Diameter tolerance of +0.000 -0.005" has therefore been applied, so that the same fitting satisfies the requirements of both specification.

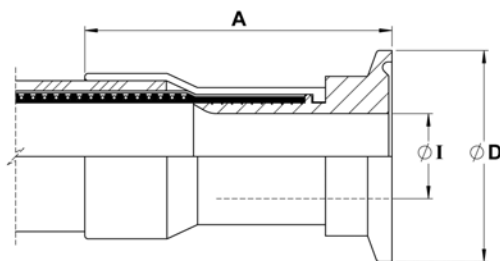

MINI-SANITARY TRICLAMP (TRICLOVER) FITTINGS

Nominal Hose Size	Nominal Pipe Size	*Fitting Length A		Flange Dia. D		*Outlet Dia. I	
		in	mm	in	mm	in	mm
1/2"	1/2" & DN10	2.8	72	0.984	25.0	3/8	9.5
1/2"	3/4"	2.8	72	0.984	25.0	5/8	16.0
3/4"	3/4"	3.1	79	0.984	25.0	5/8	16.0

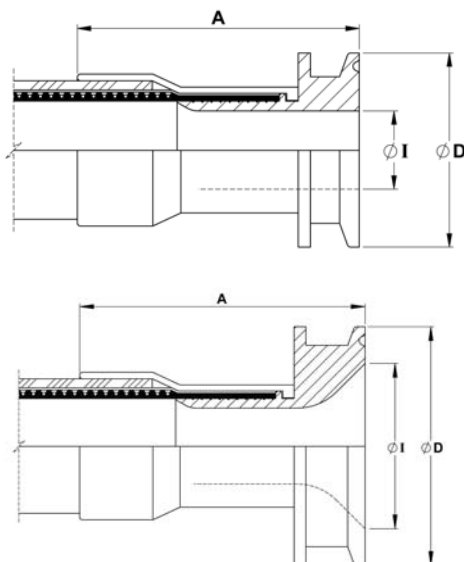

SANITARY TRICLAMPS (TRICLOVER) FITTINGS

Nominal Hose Size	Nominal Pipe Size	*Fitting Length A		Flange Dia. D		*Outlet Dia. I	
		in	mm	in	mm	in	mm
1/2"	1"	2.7	69	1.984	50.5	7/8	22.2
3/4"	DN15	3.0	77	1.156	34.0	5/8	16.0
1"	1"	3.2	82	1.984	50.5	7/8	22.2
1"	DN25	3.2	82	1.984	50.5	1	26.0
1"	1 1/2"	3.2	82	1.984	50.5	1 3/8"	34.9
1 1/2"	1 1/2"	3.9	98	1.984	50.5	1 3/8"	34.9
1 1/2"	DN40	3.9	98	1.984	50.5	1 1/2"	38.0
2"	2"	4.1	103	2.516	64.0	1 7/8"	47.6
2	DN50	4.1	103	2.516	64.0	1.975	50.0
2"	2 1/2"	4.3	110	3.047	77.5	2 3/8"	60.3
2"	DN65	4.3	110	3.047	77.5	2.600	66.0
2"	3"	4.3	110	3.579	91.0	2 7/8"	73.0
2"	DN80	4.3	110	4.176	106.0	3.191	81.0

*Fitting Lengths listed are for RC Grade Hose end fittings. SS and PB Grades end fittings are shorter in length.

CORROLINE 90° ELBOW SANITARY TRICLAMP (TRICLOVER) FITTINGS

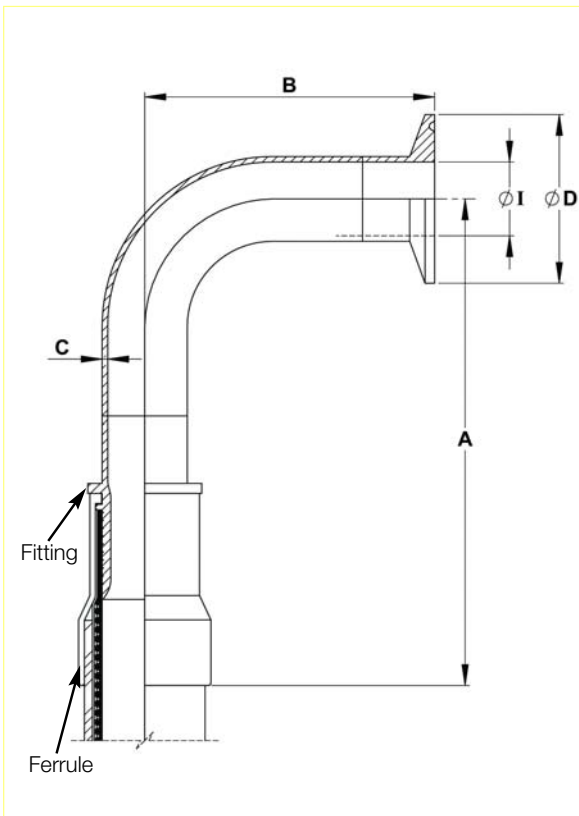

End Fitting Specification

- Generally in accordance with BS4825:Pt 3 and ASME BPE-a-2007

End Fitting Materials

- Fittings in Grade AISI 316L = EN 1.4404 = BS 316 S11
- Internal Bore average 15µin Ra, Electropolished if required
- Ferrules, most in Grade 304 SS, some sizes in Grade 316 SS

Temperature and Pressure Ratings

For Standard Clamp and Standard (EPDM) Gasket

- Pressures up to 230 psi (16 Bar)
- Temperatures up to 250°F (120°C)
- Higher Pressures and Temperatures with Special Clamps and Gaskets

Outlet Diameters

The outlet diameters as listed are in accordance with BS4825. The ASME specification, however, requires these diameters to be 0.005" (0.125mm) less in each case. An Outlet Diameter tolerance of +0.000 -0.005" has therefore been applied, so that the same fitting satisfies requirements of both specifications.

Nominal Hose Size		Centre Line To Fitting End A		Centre Line to Face B		Flange Diameter D		*Outlet Diameter I	
in	mm	in	mm	in	mm	in	mm	in	mm
1/2	13	5.78	147	1.60	41.0	0.984	25.0	3/8	9.5
3/4	20	6.41	163	1.60	41.0	0.984	25.0	5/8	16.0
1	25	6.53	166	2.00	51.0	1.984	50.5	7/8	22.2
1 1/2	40	7.99	203	2.75	70.0	1.984	50.5	1 3/8	34.9
2	50	9.33	237	3.50	88.9	2.16	64.0	1 7/8	47.6

CORROLINE DIN11851 FEMALE FITTINGS PTFE LINED and NON-LINED

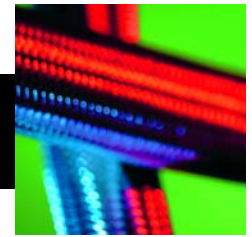

End Fitting Specification

- Generally to German DIN 11851 specifications.

Temperature & Pressure Ratings

- Sizes up to 1 1/4" MWP = 40 Bar (580 psi) up to 130°C (266°F)
- Sizes 1 1/2" & 2" MWP = 25 Bar (360 psi) up to 130°C (266°F)

Except where the applicable hose pressure/temperature ratings are lower (page 6).

End Fitting Materials

- PTFE Lined Spigots in Grade 316L SS
- Non-Lined Spigots in Grade 1.4571*
- Nuts in Grade 304 SS
- Ferrules, most in Grade 304 SS, some sizes in Grade 316L SS

*1.4571 is a special grade of 316 stainless steel, equivalent to AISI 316Ti

DIN11851 FEMALE FITTING, NON-LINED

Nominal Hose Size = 'I' Dia.		*Fitting Length A		Fitting Inner Diameter I		Fitting Thread Size
in	mm	in	mm	in	mm	
1/2	15	2.58	65	0.375	9.53	Rd 34 x 1/8"
3/4	20	2.99	76	0.625	15.88	Rd 44 x 1/6"
1	25	3.19	81	0.797	20.24	Rd 52 x 1/6"
1 1/4	32	3.82	97	1.03	26.21	Rd 58 x 1/6"
1 1/2	40	3.82	97	1.25	31.75	Rd 65 x 1/6"
2	50	3.94	100	1.75	44.45	Rd 78 x 1/6"

*Fitting Lengths listed are for RC Grade Hose end fittings. SS and PB Grades end fittings are shorter in length.

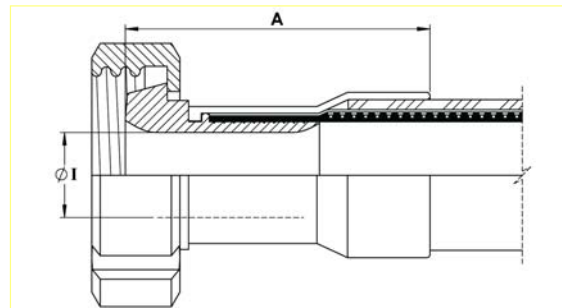

DIN11851 FEMALE FITTING, PTFE LINED

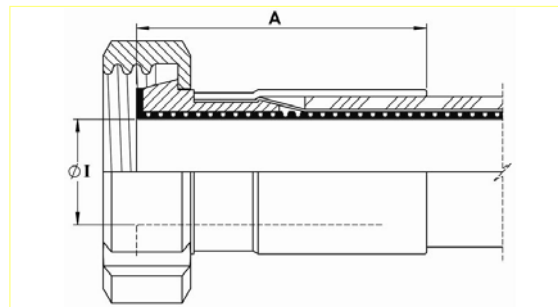

Nominal Hose Size = 'I' Dia.		*Fitting Length A		Fitting Inner Diameter I		Fitting Thread Size
in	mm	in	mm	in	mm	
1/2	15	2.00	51	0.53	13.50	Rd 34 x 1/8"
3/4	20	2.17	55	0.78	19.80	Rd 44 x 1/6"
1	25	2.76	70	1.03	26.10	Rd 52 x 1/6"
1 1/4	32	2.52	64	1.25	31.75	Rd 58 x 1/6"
1 1/2	40	2.99	76	1.53	38.80	Rd 65 x 1/6"
2	50	3.54	90	2.03	51.50	Rd 78 x 1/6"

*Fitting Lengths listed are for RC Grade Hose end fittings. SS and PB Grades end fittings are shorter in length.

CORROLINE 37° JIC FEMALE FITTINGS and NPT MALE and FEMALE UNIONS

■ End Fitting Specification

- SAE J514 37° Flare JIC Female Fitting
- 37° JIC Male-to-NPT Male/Female Adaptors
- NPT Threads to ANSI B2.1

■ Temperature and Pressure Ratings

Same Maximum Working Pressure and Temperature as for the relevant size of Corroline Hose, on page 6

■ End Fitting Materials

- Spigots in Grade 316
- Nuts in 316L SS
- Ferrules, most in Grade 304 SS, some sizes in Grade 316L SS

Note - Not usable with SAE 45° Flare fittings which have the same thread.

Alternatives - Can be supplied in other materials, such as zinc plated carbon steel, Hastelloy, Monel etc.

37° JIC FEMALE FITTING

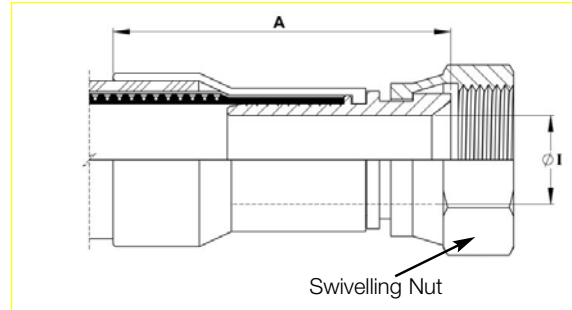

Nominal Hose Size		37° JIC Thread Size	*Fitting Length A		Fitting Inner Diameter I	
in	mm	in	in	mm	in	mm
1/2	13	3/4 -16	2.76	70	0.38	9.5
3/4	20	1 1/16 -12	3.07	78	0.63	15.9
1	25	1 5/16 -12	3.23	82	0.80	20.2
1 1/2	40	1 7/8 -12	4.00	102	1.25	31.7
2	50	2 1/2 -12	4.33	110	1.75	44.4

*Fitting Lengths listed are for RC Grade Hose end fittings. SS and PB Grades end fittings are shorter in length.

JIC TO NPT MALE UNION (Including a JIC MALE-TO-NPT MALE ADAPTOR)

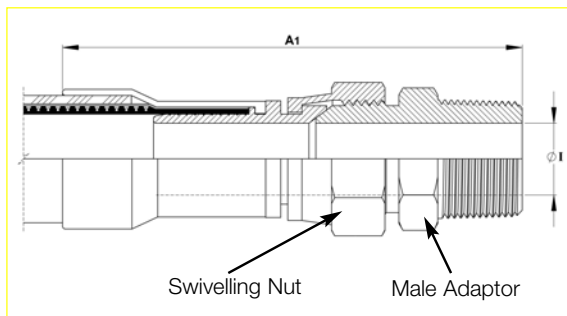

JIC TO NPT FEMALE UNION (Including a JIC MALE-TO-NPT FEMALE ADAPTOR)

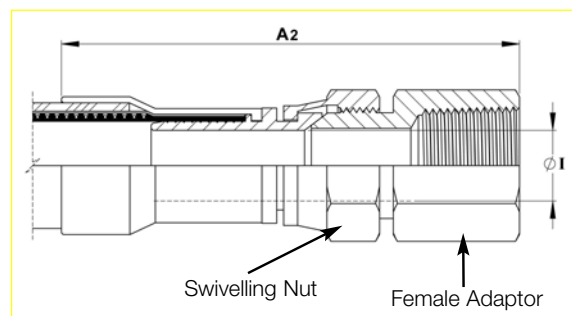

Nominal Hose Size		*Male Union Length A1		*Female Union Length A2		Fitting Inner Diameter I	
in	mm	in	mm	in	mm	in	mm
1/2	13	4.13	105	4.25	108	0.38	9.5
3/4	20	4.92	125	4.80	122	0.63	15.9
1	25	5.43	138	5.12	130	0.80	20.2

*Fitting Lengths listed are for RC Grade Hose end fittings. SS and PB Grades end fittings are shorter in length.

CORROLINE TUBE ADAPTOR (GROOVED STANDPIPE) FITTINGS

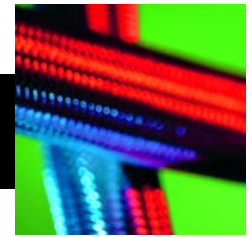

■ Specifications

- Compatible with existing Industrial Standard Tube Fitting Components.

■ Temperature and Pressure Ratings

As for the relevant size of hose on Page 6.

■ End Fitting Materials

- Fitting in Grade 316L SS
 - Ferrule (for hose attachment) in Grade 304 or 316L SS

Alternatives -Can be supplied with matching Female Nuts & Ferrules (clamping Ferrules) to suit.

NON LINED TUBE ADAPTOR (GROOVED STANDPIPE) FITTING

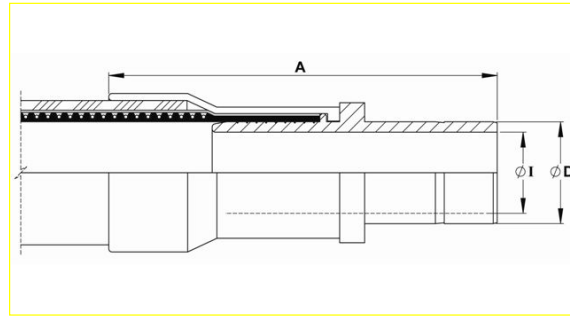

Nominal Hose Size		*Fitting Length A		Diameter D		Fitting Inside Diameter I	
in	mm	in	mm	in	mm	in	mm
3/4	20	3.10	79.0	3/4	19.05	0.58	14.70
1	25	3.58	91.0	1	25.4	0.80	20.32
1 1/2	40	4.49	114.0	1 1/2	38.1	1.25	31.75

*Fitting Lengths listed are for RC Grade Hose end fittings. SS and PB Grades end fittings are shorter in length.

CORROLINE NPT and BSPT FIXED MALE and NPT FIXED FEMALE FITTINGS

■ End Fitting Specification

NPT Taper Threads to American National Standard Pipe Taper Thread design to ANSI B2.1

BSPT Threads to British Standard Pipe Taper Thread design to BS21

Alternatives - Parallel Threads, Metric Threads and Others.

■ End Fitting Materials

- Fittings in Grade 316L SS
- Ferrules, most in Grade 304 SS, some sizes in Grade 316L SS

Alternatives - Fittings in Zinc Plated Carbon Steel

FIXED MALE NPT or BSPT

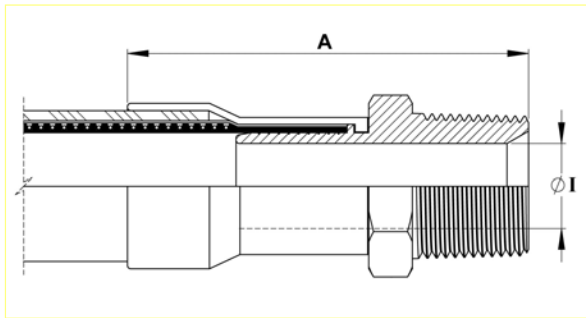

Nominal Hose Size		NPT or BSPT Thread Size	*Fitting Length A		Fitting Inside Diameter I	
in	mm	in	in	mm	in	mm
1/2	13	1/2	3.30	84	0.38	9.53
3/4	20	3/4	3.74	95	0.63	15.88
1	25	1	4.13	105	0.80	20.24
1 1/4	32	1 1/4	4.90	124	1.00	26.20
1 1/2	40	1 1/2	5.19	132	1.25	31.75
2	50	2	5.78	142	1.75	44.45

*Fitting Lengths listed are for RC Grade Hose end fittings. SS and PB Grades end fittings are shorter in length.

FIXED FEMALE NPT

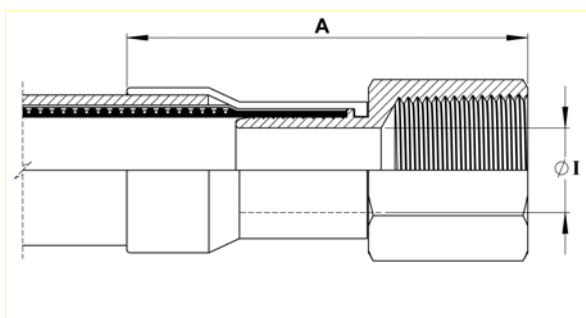

Nominal Hose Size		NPT Thread Size	*Fitting Length A		Fitting Inside Diameter I	
in	mm	in	in	mm	in	mm
1/2	13	1/2	3.42	87	0.38	9.53
3/4	20	3/4	3.66	93	0.63	15.88
1	25	1	4.13	105	0.80	20.24
1 1/2	40	1 1/2	4.80	122	1.25	31.75
2	50	2	4.96	126	1.75	44.45

*Fitting Lengths listed are for RC Grade Hose end fittings. SS and PB Grades end fittings are shorter in length.

CORROLINE BSP 60° CONE SEAT FEMALE UNIONS and BSP FLAT SEAT LUG NUT FEMALE FITTINGS

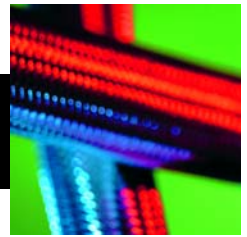

■ End Fitting Specification

BSPP Threads to British Standard Pipe Parallel Thread design to BS21, 60° Cone Seat design, or Flat Seat.

Alternatives - Cone Seat Female Union Fittings can be supplied with a BSPP/BSPT Taper Male Adaptor if required.

■ End Fitting Materials

- Spigots in Grade 316L SS
- Nuts in Grade 316L SS
- Ferrules, most in Grade 304 SS, some sizes in Grade 316L SS

Alternatives

- Cone Seat Female Unions can be supplied in Zinc Plated Carbon Steel if required.
- Lug Nuts can be supplied in Gun Metal (Bronze) if required.

BSP 60° CONE SEAT FEMALE UNION FITTING

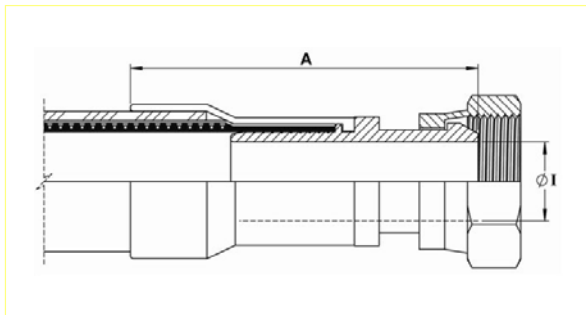

Nominal Hose Size		NPT or BSPT Thread Size	*Fitting Length A		Fitting Inside Diameter I	
in	mm	in	in	mm	in	mm
1/2	13	1/2	3.27	83	0.37	9.35
3/4	20	3/4	3.62	92	0.63	15.88
1	25	1	3.86	98	0.80	20.24
1 1/4	32	1 1/4	4.25	108	1.00	25.4
1 1/2	40	1 1/2	4.65	118	1.25	31.75
2	50	2	4.80	122	1.75	44.45

*Fitting Lengths listed are for RC Grade Hose end fittings. SS and PB Grades end fittings are shorter in length.

BSP FLAT FACE LUG NUT FEMALE FITTING

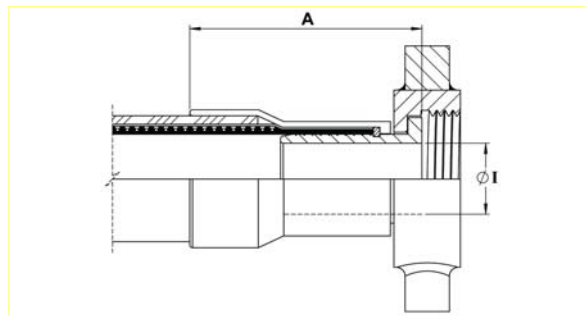

Nominal Hose Size		BSPP Thread Size	*Fitting Length A		Fitting Bore Diameter I	
in	mm	in	in	mm	in	mm
1	25	1	3.70	94	0.80	20.24
1 1/2	40	1 1/2	3.66	93	1.25	31.75
2	50	2	3.70	94	1.75	44.45

*Fitting Lengths listed are for RC Grade Hose end fittings. SS and PB Grades end fittings are shorter in length.

CORROLINE DIP PIPES

FIXED DIP PIPES

Description

Fixed Dip Pipes are fairly rigid, thick wall PTFE tubes, either straight or 90° elbowed, which are directly crimped to the end of Corroline hoses. They are designed for insertion into drums, tanks and reaction vessels in order to suction drain (or inject) process fluids transferred through the hose.

Materials

Standard dip pipes are in anti-static (AS) PTFE.

How to order

Specify the size and material of the dip pipe, whether it is straight or 90° elbowed. Give the length of the find leg of the dip pipe and the length of the rest of the hose assembly separately.

Maximum Working Pressures

Dip Pipes are normally only tested to 4 Bar Pressure, and are not suitable for use at pressures higher than 3 Bar. They are usable at negative pressure up to full vacuum.

If higher pressure ratings are required, consult Aflex Hose.

Lengths

Dip Pipes are supplied as standard in 1 metre lengths, but can be supplied in any length to individual requirements.



Nominal Hose Bore Size		Approximate Dip Pipe Dimensions			
		Outside Diameter D		Inside Diameter I	
in	mm	in	mm	in	mm
3/4	20	0.87	22	0.51	13
1	25	1.14	29	0.83	21
1 1/2	40	1.54	39	1.00	27
2	50	2.17	55	1.58	40

FIXED DIP PIPE (STRAIGHT)

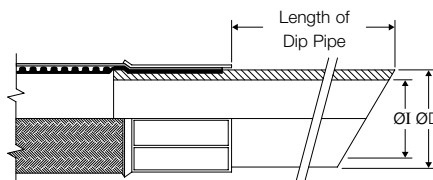

DETACHABLE DIP PIPES

Description

As Fixed Dip Pipes above, but connected to the hose through an end fitting, not by crimping direct to the hose.

Design

A straight, or 90° elbowed anti-static PTFE Dip Pipe, fitted with a Flange or Cam & Groove Male PTFE Lined & Flared end fitting.

The most usual end fitting is a Cam Male (as shown), so the dip pipe can then be connected to a hose with a Cam Female end fitting.

Specifications

As above for Fixed Dip Pipes.

DETACHABLE DIP PIPE

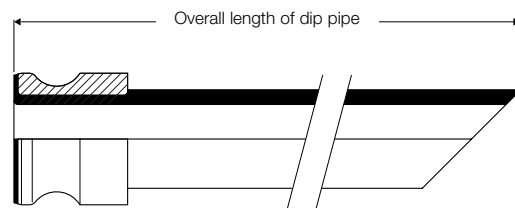

CORROLINE STANDARD AND PHARMATAG LABELLING AND COLOUR CODING SYSTEMS

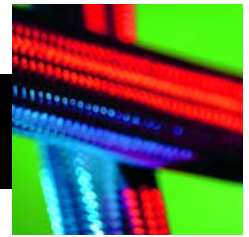

STANDARD LABELLING

All Corroline hose assemblies are labelled with the following information:

- Manufacturers Name (Aflex Hose Ltd)
- Hose Size and Grade
- Max. Working Pressure
- Unique Serial Number
- Month & Year of Manufacture
- Aflex Hose Telephone Number
- CE Mark (if applicable)

This information is normally vibro-etched on to a loose stainless steel Ring mounted on the hose.

In some cases, at the discretion of Aflex Hose, the information may be etched on to a thin stainless steel plate which is clamped to the hose, or on to the end fitting ferrule at one end. This may be necessary for example, if the customer requires additional information which may not fit on to a Ring.

Customers may specify which labelling system they require, and may request additional information on the label.



PHARMATAG LABELLING AND COLOUR CODING

Pharmatag Labelling and Colour Coding (Patent Pending)

A label and/or Colour Code is encapsulated on to the braid by a transparent rubber cover which is integrally vulcanised and fully bonded to the rubber cover on the hose. The label is replaceable if required.

Further information is available on the Pharmatag product information document on the website.



Colour Coding

A coloured PTFE spiral strip is wound on to the hose.

It can be left loose, or it can be encapsulated under a transparent, heat-shrunk polyolefin sleeve.



CORROLINE HOSE: SPECIAL USAGE CONDITIONS

■ PTFE Hose - Use with Halogens

When PTFE lined hose is used with the halogens Chlorine and Fluorine, or any corrosive halogen compounds which diffuse easily and are gaseous for example phosgene, then trace quantities may diffuse through the PTFE liner to the outside.

Only trace quantities are required, mixed with atmospheric moisture, to create a serious corrosion condition with stainless steel wire braid in particular.

Also, if any Halogen compounds are present in the environment external to the hose (for example, salt in a sea water spray), and if the temperature of the hose exceeds 50°C, there is a serious risk of "Chloride Stress Corrosion" of the stainless steel wire braid on the hose.

For such applications, always use the alternative braid materials, either HB or KYB (for fluorine & chlorine) or PB (for external chlorides).

■ "Penetrating" Fluids and Gases

Like other plastics and rubbers, in certain special circumstances PTFE is sometimes subject to diffusion through the tube wall, dependant upon the nature of the chemical, and the pressure and temperature of operation.

As mentioned above, Halogens represent a specific problem. Automotive fuels, on the other hand, diffuse much less through PTFE than through other plastics, like nylon.

Some other types of penetrating fluids can also diffuse through PTFE to varying degrees, which may or may not present a problem. Known examples are sulphur trioxide, glacial acetic acid and methyl methacrylate.

Consult with Aflex Hose if these, or any other gases or fluids which are known to be penetrating are to be used.

■ Gas/Fluid Cycling

There are some applications where the fluid passing through the hose turns into a gas, then back into a fluid, then into a gas etc., in a cyclic sequence.

This is normally associated with changes in temperature and/or pressure.

For complex reasons these conditions are extremely damaging to the hose liner, whatever material it is made from.

For example, hoses are sometimes used to pass steam, water, steam etc into rubber moulding presses, in order to heat the mould, then rapidly cool it before reheating in the next cycle. Hoses of all types fail rapidly in such an application, and PTFE lined hose is no exception.

Consult Aflex Hose for further information if these conditions apply.

■ Connecting Assemblies for use in Applications

When being connected for use in applications, the end fittings on hose assemblies must be connected to correct mating parts in the correct way, using the correct tools - spanners, clamps, nuts and bolts etc.

The connections must be sufficiently tightened to ensure that the joint is leak-free, but must not be over-tightened as this can damage the sealing surfaces, especially with PTFE lined and flared end fittings.

In applications involving the transfer through the hose of expensive or dangerous fluids or gases, the connections must be pressure tested first before being put in to service. This should be done with some harmless media, like water or compressed air, to 1½ times the maximum working pressure of the hose assembly, as defined in this brochure.

If in doubt, consult Aflex Hose for advice.

■ Special Applications

Aflex Hose PTFE lined hose products are prohibit use in the following, special applications:

- Radioactive Applications involving high energy radiation, including Gamma radiation (degrades PTFE).
- Medical Implantation Applications (Not tested for use).
- Aerospace Applications (exclusive contract applies).
- Applications on all types of USA Military Equipment, including tanks, vehicles, weapons, FCS equipment and all others (exclusive contract applies).

QUALITY ASSURANCE, CERTIFICATION & APPROVALS and HOSE TESTING

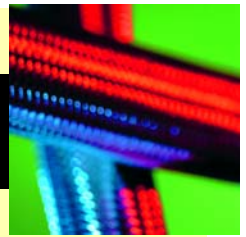

BS EN ISO 9001:2008

Aflex products are all manufactured in accordance with BS EN ISO 9001:2008 Quality Management Systems independently assessed and registered by National Quality Assurance Limited (NQA).

FDA

The Materials used to manufacture the natural PTFE Tube liner conforms to FDA 21 CFR 177.1550, and the antistatic PTFE liner conforms to FDA 21 CFR 178.3297.

3-A SANITARY STANDARDS

The PTFE used in the liner is manufactured solely from materials which meet the requirements of the 3-A Sanitary Standards.

PHARMACEUTICAL MANUFACTURERS APPROVALS

Most of the major pharmaceutical manufacturing companies in the world have audited and/or approved Aflex Hose as a Hose Supplier.

CE MARKING (EUROPE ONLY)

Aflex has been assessed by Zurich Engineering and found to comply with the Pressure Equipment Directive 97/23/EC (European Community) Conformity Assessment Module D1, approved to CE Mark applicable hose products, accompanied by a Hose Usage Data Sheet, and a Declaration of Conformity.

ATTESTATIONS OF CONFORMITY TO ATEX DIRECTIVE 94/9/EC (POTENTIALLY EXPLOSIVE ATMOSPHERES)

Available for hose and assemblies for components used in Gas Zones 1 & 2 and Dust Zones 21 & 22, when applicable.

MATERIAL CERTIFICATION TO EN10204

Available for all the hose or hose assembly components.

CERTIFICATES OF CONFORMITY TO EN45014

Are available for all products.

HOSE TESTING

Each assembly is pressure tested to 1.5 times maximum working pressure before despatch, and pressure test certificates can be supplied.

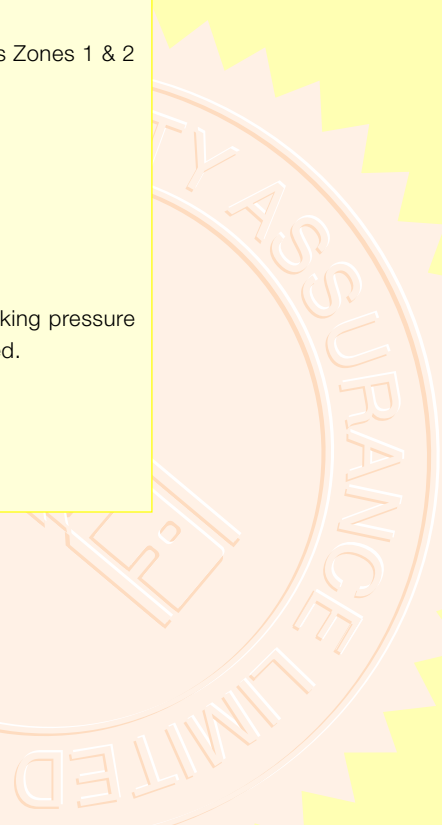

HOSE CONFIGURATION & LENGTH CALCULATIONS

- for BEND RADIUS

■ Hose Configuration Requirements

Hose Assemblies are usually connected at both ends in service. They may then either remain in a fixed, or static configuration or in a flexing, or dynamic configuration.

Whether static or dynamic, the First Rule concerning the configuration of the hose is that the bend radius of the hose must never be less than the Minimum Bend Radius (MBR) for the hose as listed in the relevant hose brochure.

The most common situation when this is likely to occur is when the hose is flexed at the end fitting, with stress being applied to the hose at an angle to the axis of the end fitting. Typically, this happens either because the length of the hose is too short, or because the weight of the hose plus contents creates a stress at an angle to the end fitting.

The Second Rule, therefore, if possible, is to design the configuration to ensure that any flexing in the hose takes place away from the end fittings.

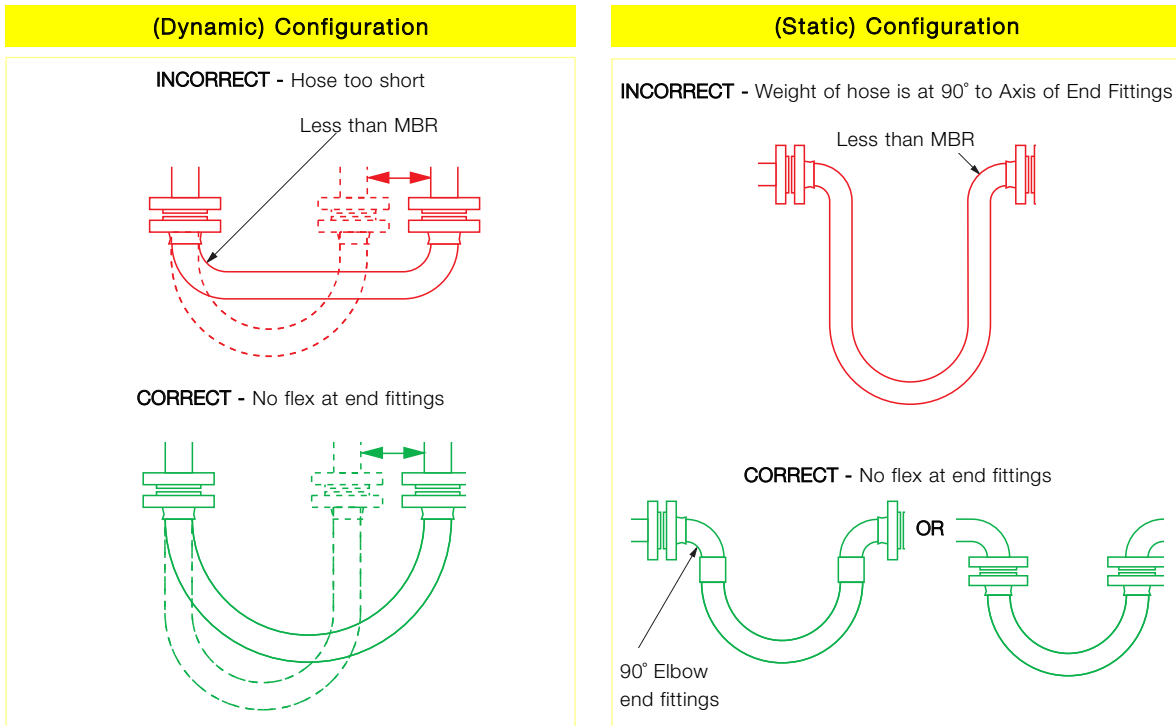

HOSE CONFIGURATION & LENGTH CALCULATIONS - ABRASION & TORQUE

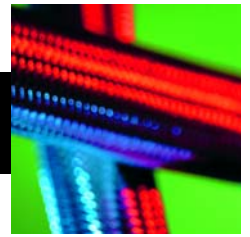

The Third Rule is that the hose configuration should always be designed, and supported where necessary, to avoid any possibility of external abrasion.

In some cases, the length, configuration and angle of the hose can be designed to avoid abrasion. In others, static or moving support frames or support wheels are required.

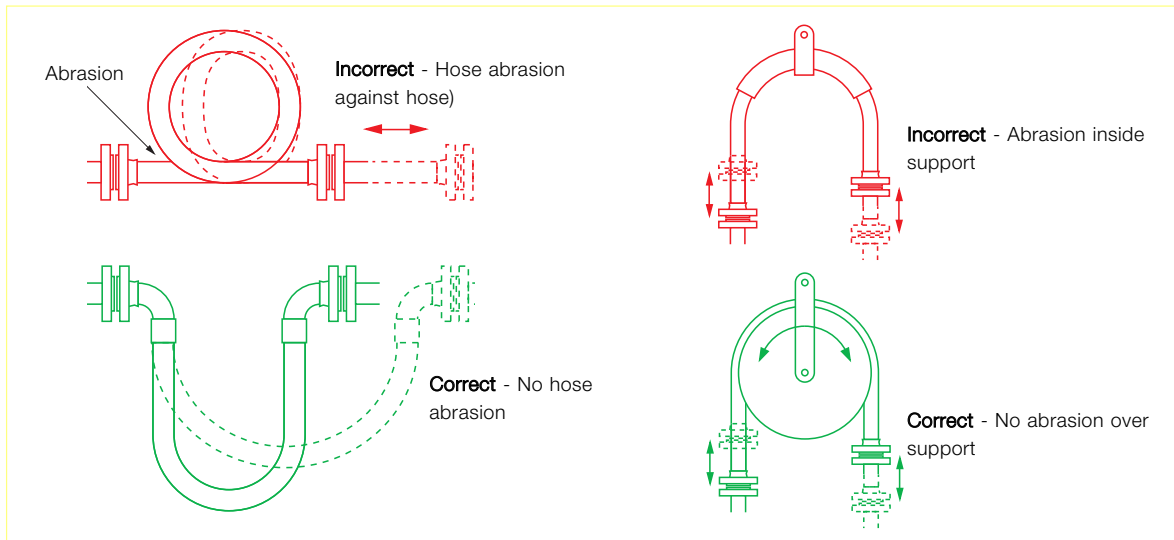

The Fourth Rule is that the hose must not be subjected to torque, either during connection, or as a result of the flexing cycle.

Torque (twist) in the hose can be applied during connection if the hose is accidentally twisted, or if the second end being connected is a screwed connection, and the hose is subjected to torque during final tightening.

In a flexing application, if any flexing cycle of the hose occurs in 3 dimensions instead of 2, then torque will also occur:

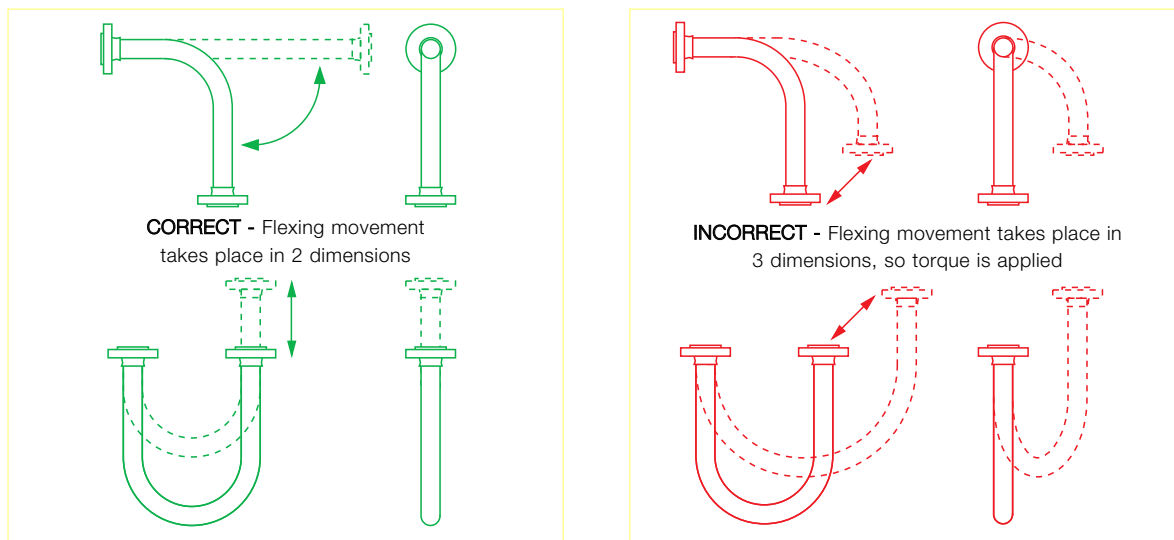

Both Corroflon and Corroline hose have good resistance to a small level of torque, much better resistance than rubber or SS hose types, but it is still the best practice to take whatever steps are necessary to eliminate torque. If in doubt, consult Aflex Hose.

HOSE CONFIGURATION & LENGTH CALCULATIONS

- for LENGTH CALCULATIONS

Calculating The Hose Length

The formula for calculating the bent section of the hose length around a radius is derived from the basic formula that the circumference of a circle = $2\pi R$, where R = the radius of the circle, and π = a constant, = 3.142.

So, if the hose goes around a 90° bend, which is $\frac{1}{4}$ of a full circumference, and the radius of the bend is R , then the length of the hose around the bend is = $\frac{1}{4} \times 2\pi R$. Or half way round, in a U-shape, = $\frac{1}{2} \times 2\pi R$.

Note :

In calculating the length of a hose assembly, the (non-flexible) length of the end fittings must be added in, also the length of any straight sections of hose, as in the following example:

Example :

To calculate the length for a 2" bore size hose with flange end fittings, to be fitted in a 90° configuration with one leg 400mm long, the other 600mm long.

$$\begin{aligned} \text{Length of Bent Section (yellow)} &= \frac{1}{4} \times 2\pi R \text{ (334)} \\ &= \frac{1}{4} \times 2 \times 3.142 \times 334 = \mathbf{525\text{mm}} \end{aligned}$$

$$\begin{aligned} \text{Length of top, Straight Section, including the top end fitting length} \\ &= 600 - 334 = \mathbf{266\text{mm}} \end{aligned}$$

$$\text{Length of bottom end fitting} = \mathbf{66\text{mm}}$$

$$\text{Total length of Hose Assembly} = 525 + 266 + 66 = \mathbf{857\text{mm}}$$

Things to consider

- A hose will normally take the longest radius available to it to go around a corner, not the MBRI! Also - always remember to include the **non-flexible** end fitting lengths.
- In dynamic applications, remember to always calculate the lengths for the most extended configuration during the flexing cycle, not the least extended.
- If the configuration is simply too complex for calculation, then obtain a length of flexible tubing of some kind, mark on paper, or a wall, or floor, or both where the connection points will be relative to each other, scaled down if necessary, then manually run the flexible tubing between them with full radii round bends. Measure the extended length, then scale up if necessary to determine the approximate length of the hose.

If in doubt, consult Aflex Hose.

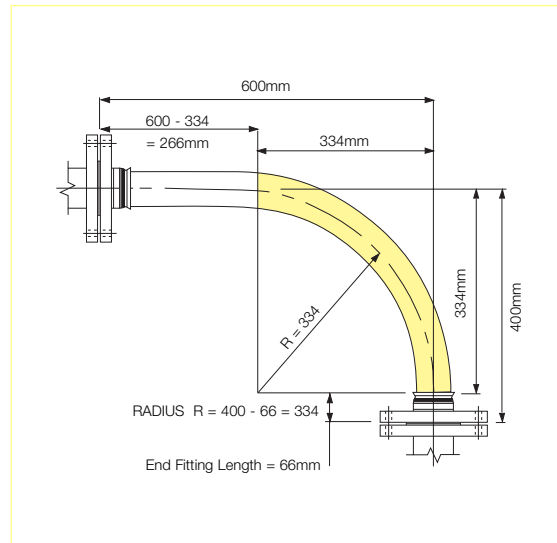
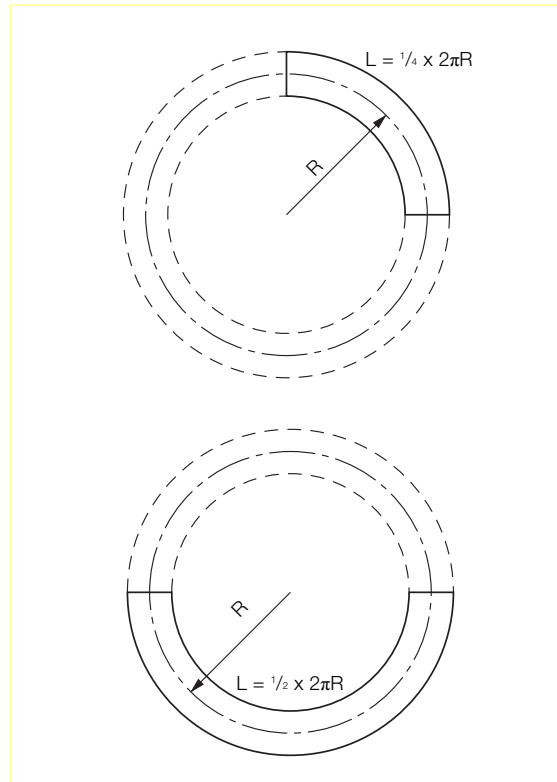

CONDITIONS OF SALE

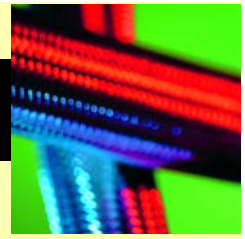

General

Aflex PTFE hose products have not been designed or tested to be suitable for use in any **Aerospace, Medical Implantation or Radioactive applications**, nor is it suitable for use in any **USA military vehicles, weapons or equipment** and such use is therefore strictly prohibited unless written approval from Aflex Hose Ltd has been given.

Aflex Hose Ltd will not accept liability for any failures of the Aflex Hose Products which are caused by customers failing to perform their Responsibilities as specified in these Conditions of Sale.

It is the customer's strict Responsibility to review all of the usage limitations given for the hose which he intends to use in an application, to ensure that the application conditions are in compliance with those usage limitations. The usage limitations are specified both on this page, and throughout the relevant sections under "Products and Information" on the Aflex Hose website. Customers must always consult the latest, up to date information, which is available and downloadable from the Aflex website, or request from Aflex Hose Ltd.

It must be accepted, however, that the usage limitations specified elsewhere in the Hose Product Information and on this page are intended as a guide only, since every possible factor in every type of application cannot possibly be covered. It is therefore the Customer's Responsibility to ensure the design suitability and safety of the products in their intended applications, giving particular consideration to the chemical and electrostatic compatibility of the fluids or gases passing through, the possibility of diffusion of fluid or gases through the PTFE hose lining, the possibility of external corrosive conditions, the types and likelihood of excessive mechanical abuse, such as abrasion (internal or external), crushing, excessive flexing or vibrations etc, and any excessive temperature and/or pressure "pulsing" conditions, all of which may cause premature hose failure. It is also the Customer's Responsibility to consider, and take account of the degree of risk involved in any hose failure, including the provision of adequate protection in the event of any risk to employees or the general public. In applications where any type of hose failure would lead to financial losses if the hose is not replaced immediately, it is the Customer's Responsibility to order and hold in stock spare hose(s) accordingly. It is also the Customer's Responsibility to advise Aflex Hose in writing if there are any special requirements for the hose, including cleaning, or drying, or extra testing requirements which are in addition to normal industrial standards.

If the Customer has any doubts concerning these or any other usage limitation or safety parameters, it is the Customer's Responsibility to consult Aflex Hose Ltd, to request a written response to any queries.

It is the Responsibility of the Customer to ensure that if the product is sold on, or passed on, however many times, that all the necessary information including this page and the Aflex Hose website address are also passed on to the final user, together with a specific requirement that the final user must review the usage limitations in terms of his own application.

Hose Service Life

It is not possible to guarantee a minimum service life for any of the Aflex Hose products which can be applicable for every type of application.

(For example, PTFE lined hose has been used in one application where it was cycled with hot steam, then cold water, also flexed every 17 seconds 24 hours per day, and the customer was very satisfied with a service life of 3 weeks before failure. In other light duty applications carrying pharmaceutical products, however, many Corroflon hoses are still performing satisfactorily after 20 years in service).

Service life predictions or guarantees can only be given in cases where all the relevant information concerning the application is given in writing to Aflex Hose, and Aflex Hose subsequently replies in writing prior to the order being placed.

If such a written undertaking is not sought and given, then Aflex Hose cannot be held liable for any hose product failure which the customer considers to be premature, excepting failures which are due to faulty materials or manufacturing defects.

24 Month Warranty

Aflex Hose Ltd warrants its products to be free from faulty materials or manufacturing defects from the date of the initial sale, for 24 months.

Product Failure

In the event of a product failure, Aflex Hose requests that the product should not be cut up or tampered with, but should be de-contaminated and returned to Aflex Hose, plus a decontamination certificate, for examination and analysis of the fault. The customer should also provide full details in writing of the application conditions under which the hose failed, including Pressure, Vacuum, Temperature, Flexing and any cycling of any of these, also the fluid and gases passing through the hose, and the total time that the hose has been in service. The customer may send his own witness to the examination if required. Aflex Hose will provide a full Non Conformance Report for the customer.

If faulty materials or a manufacturing defect in the hose was responsible for the failure to perform then, the maximum liability to be accepted by Aflex Hose would include the invoice value of the failed hose itself, or the invoice value of the whole customer order if appropriate, also any reasonable costs for removal and replacement of the hose, and costs for packing and despatching the failed hose back to Aflex Hose. Aflex Hose Ltd will not accept liability for any other consequential or financial losses, including, but not limited to loss of profits, loss of products or downtime costs.

Untested Hose for Self Assembly by Customers

Aflex Hose sometimes supplies "loose" hose, without end fittings attached to Self Assembly Customers, who will then cut the hose to length and attach end fittings to make up Hose Assemblies.

Self Assembly Customers must then accept the responsibility to carry out pressure testing of 100% of such assemblies to 1 1/2 times the Maximum Working Pressure before supply for end use, to validate both the hose and the end fitting attachment.

When pressure testing hoses with a plastic or rubber outer cover, the cover will mask any signs of leakage for a time. It is therefore recommended that pressure testing with air under water for a minimum test period of 5 minutes should be applied to covered hoses.

Unless the customer requests, and Aflex Hose confirm that their loose hose is pressure tested before supply, such testing is not normally applied by Aflex Hose, because this testing requirement is satisfied by the Self Assembly Customer during his own testing of the finished Hose Assembly.

The Self Assembly Customer must also accept responsibility for determining and approving the Design Suitability of the hose assemblies for their intended use before supply.

This includes determining and requesting or applying any special tests which may be identified as necessary to ensure suitability for the intended use.

Aflex Hose will only accept liability for its hose products which are assembled by customers themselves if all the hose and fitting components were either supplied by Aflex Hose or manufactured in accordance with Aflex Hose drawings, and they were assembled and tested in accordance with Aflex Hose's current Manufacturing and Testing Instructions.

Untested Hose Assemblies

Aflex Hose is sometimes requested by customers to attach non-standard end fittings to hose assemblies which they supply, and in some cases it is not possible to connect these fittings to the pressure test system. In such cases a Concession not to test is obtained from the Customer, and a label is attached to the hose assembly, warning that it requires pressure testing before use.

Force Majeure

Aflex Hose Ltd shall not be liable for any delay or default in performing in accordance with any Customers' order if the delay or default is caused by conditions beyond its control, including, but not limited to wars, insurrections, strikes, natural disasters or performance failures by Carriers, sub-contractors or other third parties outside the control of Aflex Hose Ltd.

Legal System

These Conditions of Sale are subject to English Law.



AFLEX HOSE LTD
 Spring Bank Industrial Estate, Watson Mill Lane,
 Sowerby Bridge, Halifax, West Yorkshire HX6 3BW

T: +44 (0)1422 317200 **F:** +44 (0)1422 836000
W: www.aflex-hose.com



AFLEX HOSE USA, LLC
 6111 Keller's Church Road, Unit B
 Pipersville, Pennsylvania, PA18947

T: 215 766 1455 **F:** 215 766 1688
W: www.aflex-hose.com



Certificate No. 1977

CORROLLINE/10.07.09/Rev. 0