

- 
- CHEMICAL RESISTANT
 - SELF-CLEANING
 - FLEXIBLE
 - HYGIENIC

Bioflex

SMOOTHBORE, FLEXIBLE PTFE HOSE

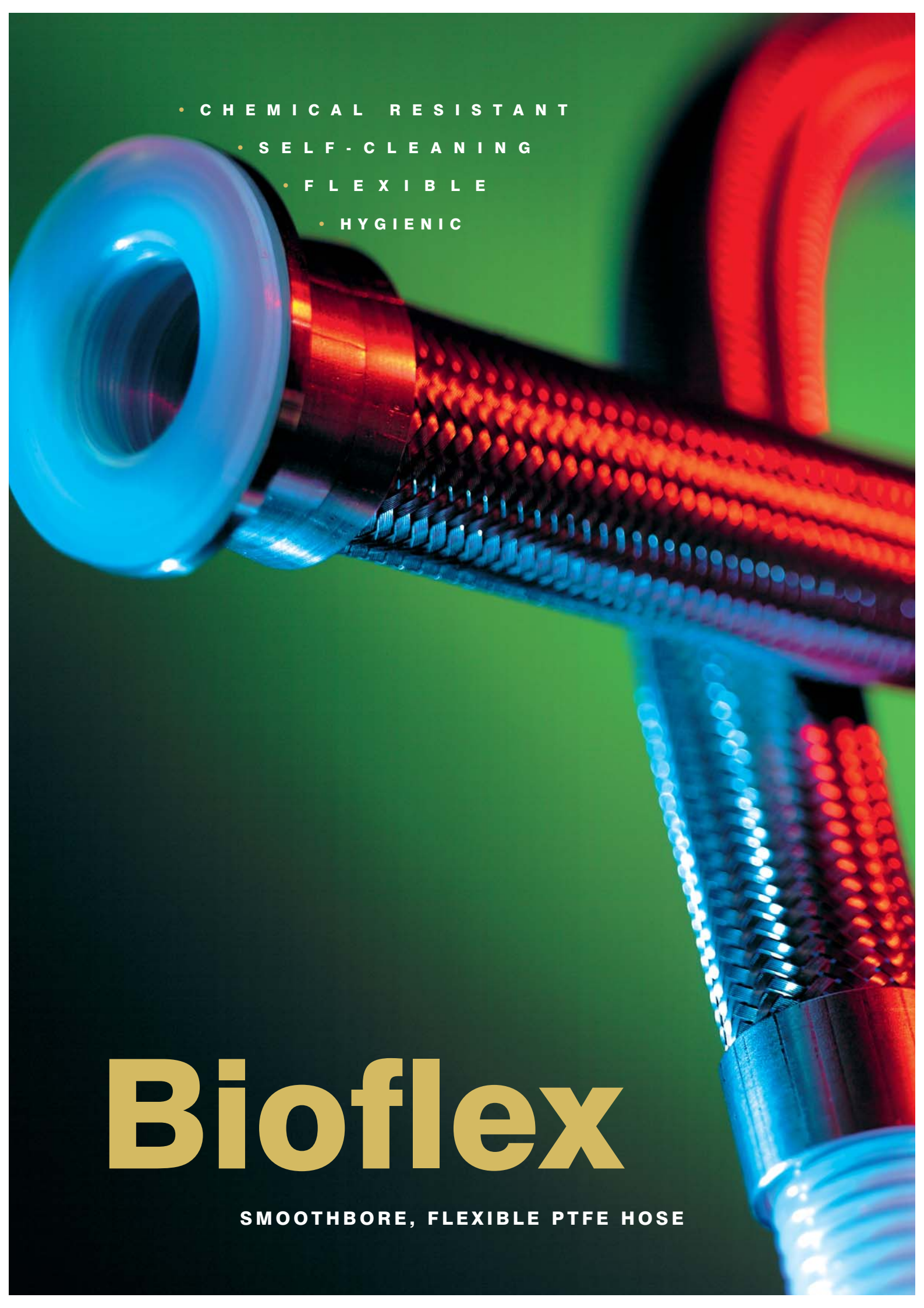

Bioflex...



The World's Leading PTFE-Lined Flexible Hose.

Contents

PTFE - The Optimum Choice For Hose Linings	Page 1
An Introduction to Aflex Hose and Bioflex	Page 2
Bioflex. Design Characteristics & Properties	Pages 3 & 4
The Bioflex Test Programme	Page 5
How to order Bioflex	Page 6
Bioflex Temperatures, Pressures & Flow Rates	Page 7
Quality Assurance, Certification, Testing & Identification	Page 8
Bioflex Size Range & Specifications	Pages 9 & 10
Bioflex Hose Liners	Page 11
Bioflex Hose Braids	Page 12
Bioflex Rubber Covers	Page 13
Bioflex External Protection Systems	Page 14
Bioflex End Fittings	Pages 15 to 26
Standard Flange Fittings	Page 15
DIN 11851 Fittings	Page 16
Saflok Cam Action Fittings & Connectors	Page 17
Standard Cam Action Fittings	Page 18
Triclover Fittings (Not PTFE Lined)	Page 19
Triclover Fittings (PTFE Lined)	Page 20
"PTFE Beaded" Triclover Fittings	Page 21
SMS & RJT Fittings	Page 22
90° Elbow Fittings	Page 23
Bioflex I-Line Fittings	Page 24
Dip Pipes	Page 25
Non-Lined Fittings	Page 26
Bioflex Steam Heated Assemblies (CH Grade)	Page 27
Bioflex Electrically Trace Heated Assemblies (ETH Grade)	Page 28
Hose Configurations and Length Calculations	Pages 29 to 31
Conditions Of Sale	Page 32
Aflex Distributors	Back Cover

PTFE - The Optimum Choice For Hose Linings

Section from a PTFE Molecule,
16 Angstrom Units long.

 = Fluorine Atom
 = Carbon Atom

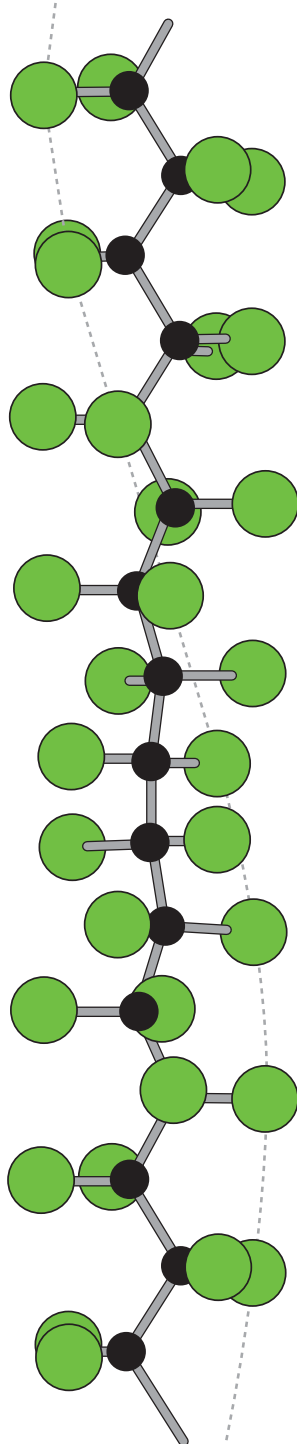

PTFE, or Polytetrafluoroethylene, comprises long-chain molecules of carbon atoms, each linked to two fluorine atoms.

The fluorine atoms provide a helical spiral which surrounds the carbon chain and protects it.

It is this structure which creates the unique properties for which PTFE is well-known.

Excellent Chemical Resistance

PTFE is renowned as the most chemically resistant material known. Only a very few, very unusual substances and conditions can affect it, like Fluorine gas at high temperature and pressure and liquid, boiling sodium metal.

PTFE lined hoses can therefore be used for a wider variety of chemicals than any other hose type, making it the ideal choice for very corrosive chemical applications and multi-product applications.

Non-Stick Surface

The use of PTFE as a surface for cookware products has demonstrated to the world how easily cleanable PTFE surfaces are.

This means that PTFE lined hoses can be purged 100% clean more quickly, easily and reliably than any other type of hose.

Excellent Temperature Range

The cookware application also demonstrates another of PTFE's many attributes - temperature resistance. PTFE itself can be used as a hose liner at temperatures from -150°C up to $+260^{\circ}\text{C}$, dependent upon the hose design and the application conditions.

This is the widest temperature range of any rubber or plastic hose lining material.

Hose Design

The only issue with PTFE as a hose lining material is the best way it can be integrated in to the hose design. This is where Aflex Hose have a proven record of success over the last 30 years.



Aflex Hose

The World's Leading Manufacturer of PTFE Flexible Hose

Aflex Hose, founded in 1973, pioneered the concept of PTFE lined flexible hose for the transfer of process fluids more than 30 years ago.

Corroflon convoluted PTFE hose and other types of PTFE hose, manufactured and supplied by Aflex, are used by major Chemical, Pharmaceutical and Food companies worldwide.

Over the years, hundreds of thousands of custom-built hoses have been designed and built to cope with the most difficult of operating conditions, and Aflex have continuously developed and expanded their product range having pioneered and introduced Antistatic hose, Polypropylene Braided hose and many other innovations in response to customer demands.

In 1998, Aflex fulfilled the most stringent demand yet.

Customers, worldwide, had always asked for the ultimate PTFE lined flexible hose... one product which incorporates the advantages of both convoluted and smoothbore designs. A product which is sufficiently flexible, like convoluted, yet which retains the advantages offered by smoothbore, like fast flow rate and cleanability.

After years of painstaking research and development, Aflex launched such a hose ... **Bioflex**.

Bioflex is a smoothbore, highly flexible, PTFE lined hose. Its design overcomes the disadvantages of conventional smoothbore and convoluted PTFE flexible hose designs, dramatically improving on many of their individual technical performance parameters.

The key feature of Bioflex PTFE hose is the PTFE liner design, which comprises integral rib sections which support the tube against kinking, vacuum and pressure, and highly compressed web sections which give a smoothbore inner surface and excellent flexibility.

Another feature is the integral PTFE lined and flared end fitting design (see next page) which is available for all the standard end fittings on Bioflex Hose Assemblies.

This provides clean, full-bore flow through the end fitting without any entrapment points - unlike conventional fittings, which introduce a bore restriction, also a crevice at the end of the fitting tail.

This PTFE lining also protects the end fitting from any corrosive media passing through the hose bore.

Today, Bioflex has become the established standard in process fluids applications all over the world, and continues to be introduced into new applications every day.

Conventional Convoluted PTFE Liner

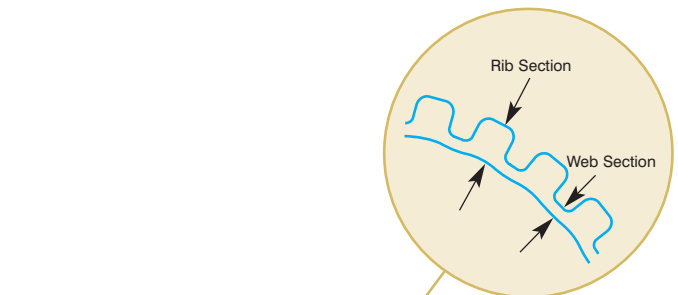
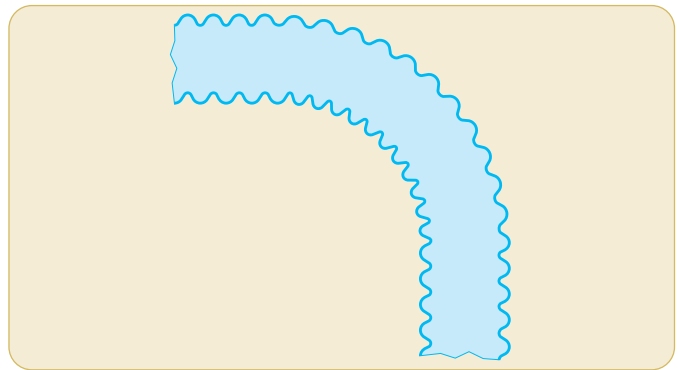

Bioflex PTFE Liner

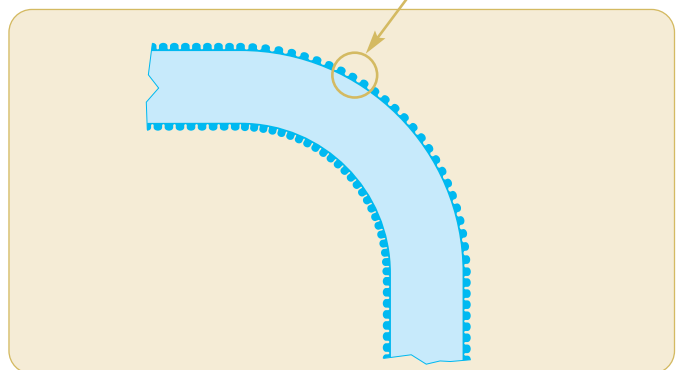

Bioflex. The World's Leading

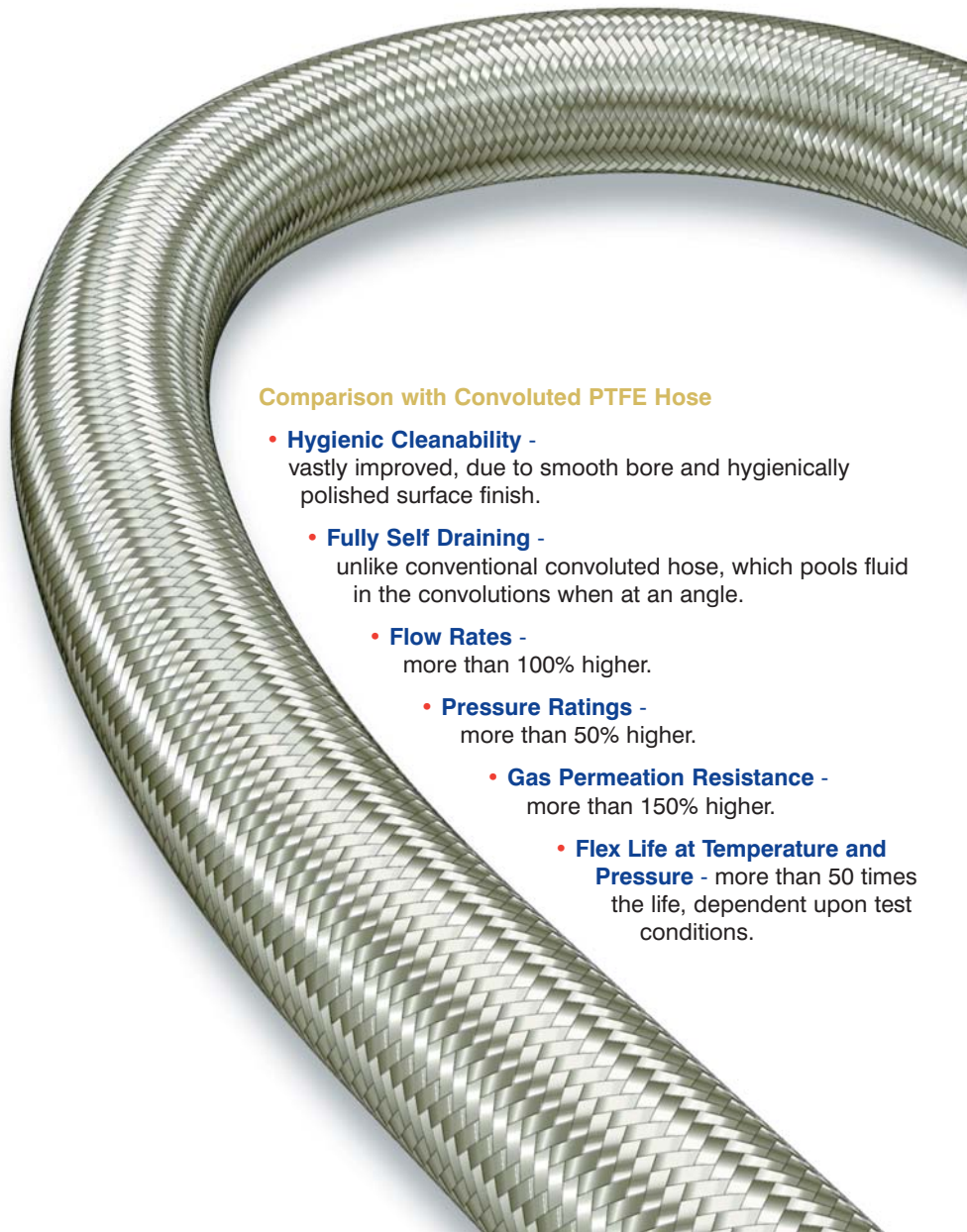

Comparison with Convoluted PTFE Hose

- **Hygienic Cleanability** - vastly improved, due to smooth bore and hygienically polished surface finish.
- **Fully Self Draining** - unlike conventional convoluted hose, which pools fluid in the convolutions when at an angle.
- **Flow Rates** - more than 100% higher.
- **Pressure Ratings** - more than 50% higher.
- **Gas Permeation Resistance** - more than 150% higher.
- **Flex Life at Temperature and Pressure** - more than 50 times the life, dependent upon test conditions.

PTFE - Lined Flexible Hose

Comparison with Silicone Rubber Hose

- **Hygienic Cleanability** - much better, due to highly polished inner surface finish.
- **Chemical Resistance** - considerably improved, particularly to strong oxidising acids and bases.
- **Temperature & Pressure Ratings** - much higher temperature and pressure capability.
- **Steam Resistance** - permanently resistant to steam sterilising (unlike silicone hose, which has a limited life).

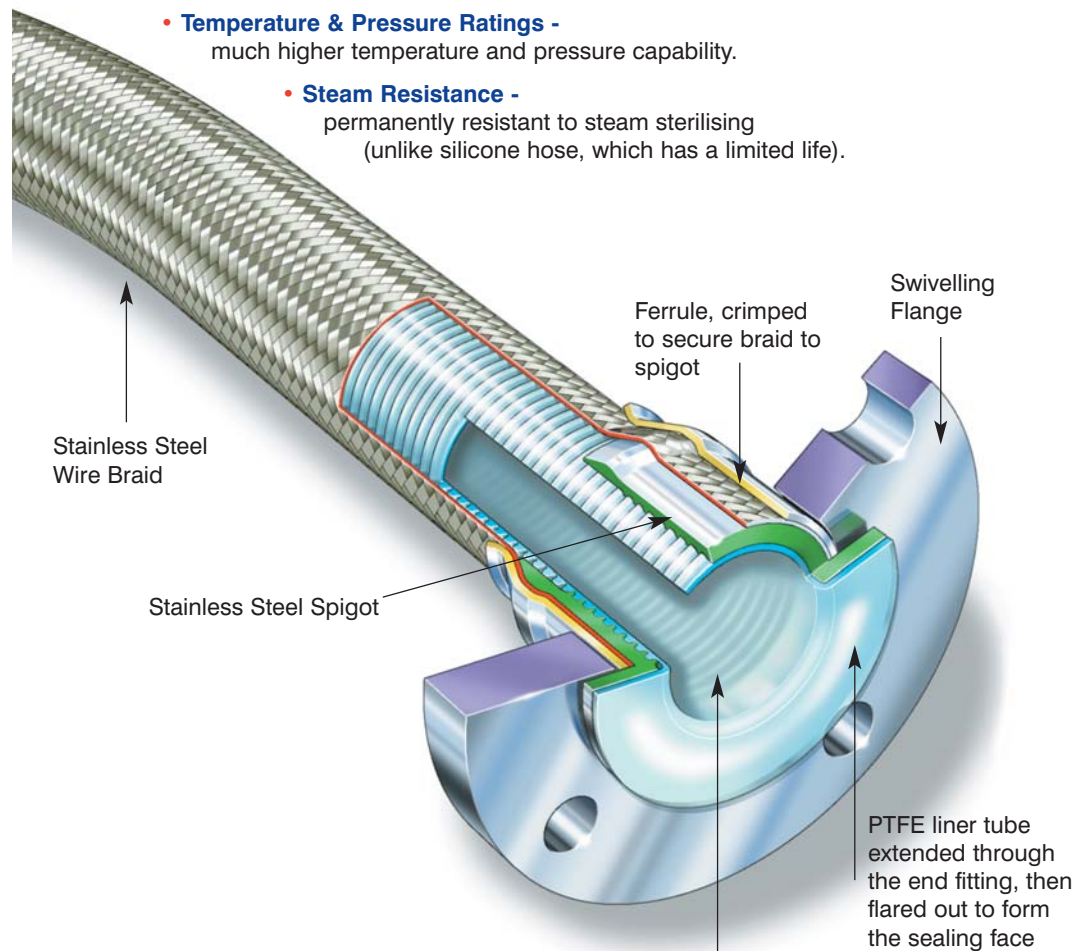

Bioflex PTFE liner tube:

- externally convoluted
- smooth bore, with slight ripples
- internal surface finish is 'mirror smooth', generated by hot polishing during manufacture

The Bioflex Test Programme

Bioflex has been designed to fulfil the most demanding of customer expectations and, as such, has been subjected to a highly complex and rigorous Proof Testing Programme, parts of which are described here.

Test No. 1. The 'Flip-Flop' Test.

The 'Flip Flop' test was invented by Aflex Hose to combine the extremes of flexing, temperature and pressure simultaneously. The hose is flexed to its Minimum Bend Radius in two opposing directions through a 240° arc. It is cycled through this flexing profile 20 times per minute, while pressurised to its Maximum Working Pressure, inside an oven heated to 180°C.

Results

Bioflex consistently achieves more than 50 times the life of standard convoluted hose.

Typically, a 1" Bioflex hose is still intact tested at 50 Bar for 100,000 cycles, whilst a 1" convoluted hose tested at 30 Bar fails due to the inner tube bursting after 1,300 cycles.

Similar results were also achieved when tested without pressure, at room temperature.

Test No. 2. The Permeability Test.

Fixed lengths of Bioflex were pressurised to 30 Bar with Helium Gas, and compared with samples of standard convoluted PTFE hose.

Results

Bioflex has more than 2.5 x the permeation resistance of standard convoluted hose. Millilitres of Helium which permeated hose, per metre, per hour:

1" Bioflex	= 138
1" Convoluted	= 371

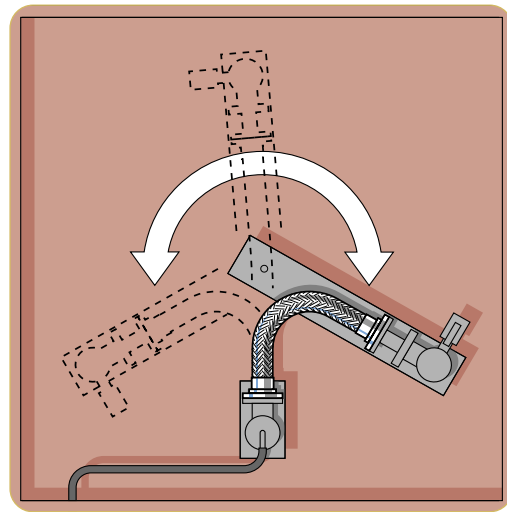
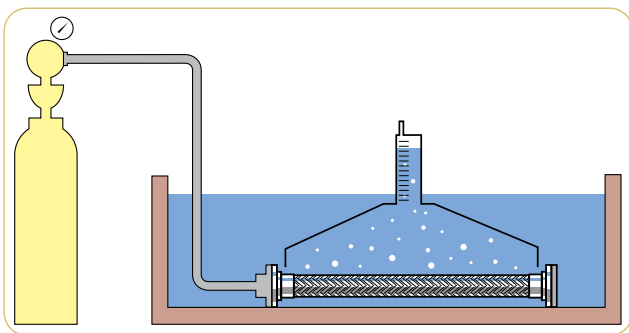

Test No. 3. The Flow Rate Test.

The test apparatus illustrated below was used to measure the flow rate of Bioflex, both in a straight configuration and coiled to its Minimum Bend Radius. The test medium was water.

Results

Comparisons were made with samples of standard convoluted hose with the same diameter on the inside of the convolutions as the Bioflex inside diameter. These show that Bioflex is capable of delivering 2 - 3 times the flow rate of convoluted hose.

Additional tests have shown that the flow rate through a Bioflex hose is actually greater than that of a convoluted hose which is one size larger. For example, 1 1/2" Bioflex has a higher flow rate than 2" convoluted hose. It is therefore possible to use a smaller Bioflex hose, fitted with full size end fittings, to replace a convoluted hose more effectively, and more economically!

This remarkable improvement is due to the fact that the turbulent flow created by the convolutions in the standard product is virtually eliminated by the much smoother bore of Bioflex.

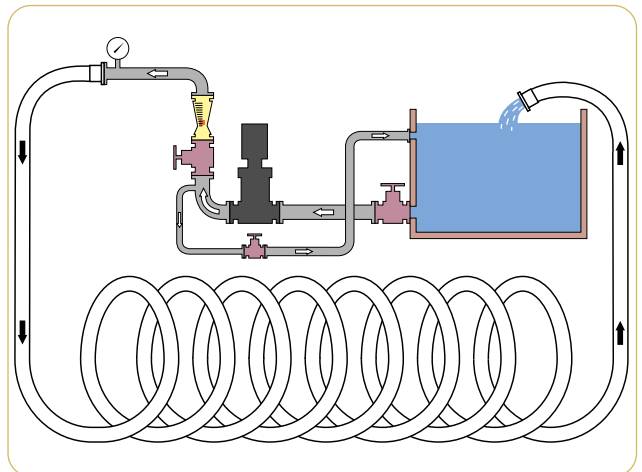

How to Order Bioflex

Bioflex Hose Assemblies

Bioflex is always custom built to individual order and is supplied in the form of finished hose assemblies, after the length, liner, braid, cover and end fittings have been decided upon.

Selecting the Hose Grade

There are two types of PTFE liner available, natural (GP) and anti-static (AS) and four types of braid, Grade 304 stainless steel (SS) polypropylene (PB), Hastelloy (HB), PVDF or Kynar (KYB). These are described on pages 11 and 12. Rubber covering and other external protection systems are also available, described on pages 13 and 14.

A hose grade is specified by using the abbreviations given. For example, Bioflex AS,PB would describe a hose with an anti-static PTFE liner and a polypropylene braid.

Step-up End Fittings

The very high flow rates of Bioflex hose relative to convoluted hose make it possible to use a smaller bore size Bioflex hose assembly with 'Step-up' size end fittings, where the end fitting size is one size larger than the hose size. Thus, a lighter weight, more flexible hose can be used without compromising the flow rate!

Selecting the Hose Length

Bioflex hose assemblies are made up to the specific lengths required. The hose length is taken as the length from the sealing face at one end of the hose to the same at the other end. The length tolerance is normally +5%-0%. Closer tolerances are available to special order.

Selecting the End Fittings

Bioflex is available with a range of 'standard' end fittings (described on pages 15-22), normally supplied hygienically PTFE lined and flared.

End Fitting Materials

All hose end fitting spigots are supplied made from Grade 316 SS, and all ferrules, swivelling nuts and flanges are from Grade 304 SS, or Grade 316 SS if Grade 304 is not available.

Grade 316 SS and Grade 304 SS, depending upon the method of manufacture, will be to one of the following specifications:

Grade	British Standard	American Standard	German/Euro Standard
316	316 S31	AISI 316	1.4401
316	316 S11	AISI 316L	1.4404
316	316 C16	CF8M	1.4408
304	304 S15	AISI 304	1.4301
304	304 S11	AISI 304L	1.4307
304	304 C15	CF8	1.4308

*Bioflex Hose Assembly Length Limitations							
Nominal Size of Hose		Minimum Hose Assembly Length*				Maximum Hose Assembly Length	
		Used Straight		Flexed Thru' 90°			
in	mm	in	mm	in	mm	mtrs	
3/8	10	4	100	5	120	20	
1/2	15	6	150	6	150	20	
5/8	16	6	150	6 1/2	160	20	
3/4	20	6	150	7	180	20	
7/8	22	8	205	9	230	20	
1	25	9	230	10	250	20	
1 1/4	32	9	230	11	280	20	
1 3/8	35	9	230	14	350	18	
1 1/2	40	9	230	15	380	17	
1 7/8	48	10	250	18	450	13	
2	50	10	250	20	500	10	

* Listed lengths are for SS, PB or KYB Braided Hose Assemblies fitted with PTFE lined fittings only. For all other specifications including rubber covered grades and non-lined ends, add 100mm up to 1" Bore, 150mm above 1" bore.

Bioflex Specifications.

Temperatures, Pressures & Flow Rates

Temperature vs Pressure

Due to its extremely strong construction, Bioflex has outstanding resistance to temperature and pressure, much higher than that of conventional convoluted PTFE lined hose.

Maximum Working Pressure (MWP) Variation with Temperature:

Hose with SS Braid as per Graph.

Hose with PB Braid, pressure as listed (Page 10) from -30°C to +80°C and 50% less from 80°C to 100°C.

Hose with RC, FP and SI grades as per Graph, BUT only within the temperature range for the particular grade of rubber cover, as given below.

Maximum Operating Temperatures (Internal Fluid Only):

SS	-70°C to +260°C
PB	-30°C to +100°C
SS,RC & SS, FP	-40°C to +140°C
SS, SI	-40°C to +180°C
KYB	-40°C to +120°C

(Subtract 20°C from the above maximum temperature limits if the temperature is external to the hose).

Flow Rates

In practice, flow rates will vary with hose flexing, fluid viscosity, end fitting design and other parameters, but Bioflex hose flow rates are always around 2 times better than convoluted PTFE hose, when comparing hose assemblies with PTFE lined (non bore-restricted) end fittings.

Bioflex Hose - Flow Rate Calculation

If it is required to determine the flow rate of a particular hose assembly, or if it is required to determine the pressure required to generate a certain flow rate, then this can sometimes be approximately calculated by the Bioflex supplier.

It should be noted that calculations can only be made for fluids with a viscosity equal to water, and for hose assemblies with PTFE lined end fittings (no bore restrictions at the ends of the hose).

The following information should be given to the supplier:

To calculate the Flow Rate in Cubic Metres per Hour:

- Pressure in Bars at the Entry into the Hose Assembly
- Pressure in Bars at the Exit from the Hose Assembly (Subtracted to calculate Pressure Drop over the Hose Length)
- The hose configuration (roughly straight, or 33% Bends, or 66% Bends, or 100% Tightly Coiled)

OR To Calculate the Pressure Drop in bars over the length of the Hose Assembly:

- Required Flow Rate in Cubic Metres per Hour
- The hose configuration (roughly straight, or 33% Bends, or 66% Bends, or 100% Tightly Coiled)

Non-Whistling

The 'whistling' noise created by turbulent flow when steam or other gases are passed through a convoluted hose is completely eliminated when using Bioflex.

Temperature & MWP Graph for Bioflex GP, SS and AS, SS

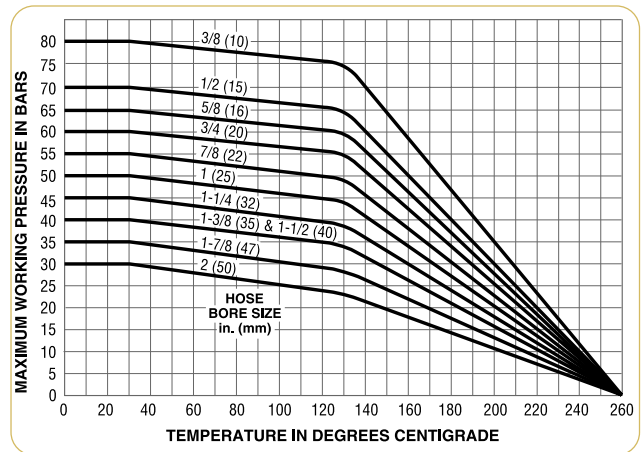

Temperature vs Vacuum

All sizes of Bioflex GP,SS and AS, SS are usable at full vacuum up to 130°C. Above this, the vacuum resistance should be reduced 1% for every degree above 130°C.

Rubber covered grades the same, BUT ONLY within the temperature limits for the type of rubber.

Bioflex

Quality Assurance, Certification and Approvals

BS EN ISO 9001:2000

Aflex products are all manufactured in accordance with BS EN ISO 9001: 2000 Quality Management Systems independently assessed and registered by National Quality Assurance Limited (NQA).

USP Class VI

Natural and Antistatic PTFE Hose Liners, Platinum Cured Silicone Rubber Covers (White and Clear) and EPDM Rubber Cover (Blue) have been tested in accordance with USP protocols and are found to conform to the requirements of USP Class VI Chapter <88>

Natural and Antistatic PTFE Hose Liners, Platinum Cured Silicone Rubber Covers (White and Clear) have also been tested in accordance with USP protocols and are found to conform to the requirements of USP Class VI Chapter <87>, the L929 MEM Elution Test and are considered non-cytotoxic.

FDA

The Materials used to manufacture the natural PTFE Tube liner conforms to FDA 21 CFR 177.1550, and the antistatic PTFE liner conforms to FDA 21 CFR 178.3297.

3-A Sanitary Standards

The PTFE used in the liner is manufactured solely from materials which meet the requirements of the 3-A Sanitary Standards

Pharmaceutical Manufacturers Approvals

Most of the major pharmaceutical manufacturing companies in the world have audited and/or approved Aflex Hose as a Hose Supplier.

CE Marking (Europe only)

Aflex has been assessed by Zurich Risk Services and found to comply with the Pressure Equipment Directive 97/23/EC (European Community) Conformity Assessment Module D1, approved to CE Mark applicable hose products, accompanied by a Hose Usage Data Sheet, and a Declaration of Conformity.

Attestations of Conformity to ATEX Directive 94/9/EC (Potentially Explosive Atmospheres)

Available for hose and assemblies for components used in Gas Zones 1 & 2 and Dust Zones 21 & 22, when applicable.

Material Certification to EN10204

Available for all the hose or hose assembly components.

Certificates of Conformity to EN45014

Are available for all products.

Hose Identification and Testing

All Aflex Hose assemblies are identified with a stainless steel identification tag, ring or ferrule, vibro etched with a unique serial number for traceability, and other relevant information.

Each assembly is pressure tested to 1.5 times maximum working pressure before despatch, and pressure test certificates can be supplied.

Bioflex Size Range

Nominal Hose Bore Size		Actual Bore Size		O/D of Tube	Braid Type	O/D of Braid or Rubber	Minimum Bend Radius
in	mm	in	mm	mm		mm	mm
3/8	10	3/8	9.5	11.96	TO	-	35
					SS	12.83	20
					RC	17.40	18
1/2	15	1/2	12.7	15.49	TO	-	60
					SS	16.6	38
					PB	19.5	38
					SS,RC/FP	21.0	60
					SI	21.0	60
					KYB	17.5	60
5/8	16	5/8	16.0	19.40	TO	-	68
					SS	20.6	45
					PB	23.3	45
					SS,RC/FP	25.0	68
					SI	25.0	68
					KYB	21.5	68
3/4	20	3/4	19.0	23.20	TO	-	75
					SS	24.5	50
					PB	27.9	50
					SS,RC/FP	30.4	75
					SI	30.4	75
					KYB	26.0	75
7/8	22	7/8	22	27.00	TO	-	92.5
					SS	28.2	60
					PB	32.0	60
					SS,RC/FP	33.2	92.5
					SI	33.2	92.5
					KYB	29.7	92.5
1	25	1	25.4	31.00	TO	-	110
					SS	32.3	70
					PB	37.7	70
					SS,RC/FP	37.3	110
					SI	37.3	110
					KYB	33.4	110
1 1/4	32	1 1/4	32	37.30	TO	-	140
					SS	39.5	100
					PB	44.3	100
					SS,RC/FP	44.5	140
					SI	44.5	140
					KYB	39.7	140
1 3/8	35	1 3/8	34.9	41.20	TO	-	160
					SS	43.1	120
					PB	47.8	120
					SS,RC/FP	48.1	160
					SI	48.1	160
					KYB	42.9	160
1 1/2	40	1 1/2	38	45.00	TO	-	180
					SS	47.0	140
					PB	50.8	140
					SS,RC/FP	52.0	180
					SI	52.0	180
					KYB	47.7	180
1 7/8	48	1 7/8	47.6	55.20	TO	-	280
					SS	57.1	190
					PB	62.0	190
					SS,RC/FP	62.1	280
					SI	62.1	280
					KYB	57.3	280
2	50	2	50.8	59.10	TO	-	300
					SS	61.0	200
					PB	66.0	200
					SS,RC/FP	66.0	300
					SI	66.0	300
					KYB	61.7	300

& Usage Specifications

SPECIAL CONDITIONS

PTFE Hose - Use with Halogens

When PTFE lined hose is used with the halogens Chlorine and Fluorine, or any corrosive halogen compounds which diffuse easily and are gaseous for example phosgene, then trace quantities may diffuse through the PTFE liner to the outside.

Only trace quantities are required, mixed with atmospheric moisture, to create a serious corrosion condition with stainless steel wire braid in particular.

Also, if any Halogen compounds are present in the environment external to the hose (for example, salt in a sea water spray), and if the temperature of the hose exceeds 50°C, there is a serious risk of "Chloride Stress Corrosion" of the stainless steel wire braid on the hose.

For such applications, always use the alternative braid materials, either HB or KYB (for fluorine & chlorine) or PB (for external chlorides).

"Penetrating" Fluids and Gases

Like other plastics and rubbers, in certain special circumstances PTFE is sometimes subject to diffusion through the tube wall, dependant upon the nature of the chemical, and the pressure and temperature of operation.

As mentioned above, Halogens represent a specific problem. Automotive fuels, on the other hand, diffuse much less through PTFE than through other plastics, like nylon.

Some other types of penetrating fluids can also diffuse through PTFE to varying degrees, which may or may not present a problem. Known examples are sulphur trioxide, glacial acetic acid and methyl methacrylate.

Consult with Aflex Hose if these, or any other gases or fluids which are known to be penetrating are to be used.

Gas/Fluid Cycling

There are some applications where the fluid passing through the hose turns into a gas, then back into a fluid, then into a gas etc., in a cyclic sequence.

This is normally associated with changes in temperature and/or pressure.

For complex reasons these conditions are extremely damaging to the hose liner, whatever material it is made from.

For example, hoses are sometimes used to pass steam, water, steam etc into rubber moulding presses, in order to heat the mould, then rapidly cool it before reheating in the next cycle. Hoses of all types fail rapidly in such an application, and PTFE lined hose is no exception.

Consult Aflex Hose for further information if these conditions apply.

Connecting Assemblies for use in Applications

When being connected for use in applications, the end fittings on hose assemblies must be connected to correct mating parts in the correct way, using the correct tools - spanners, clamps, nuts and bolts etc.

The connections must be sufficiently tightened to ensure that the joint is leak-free, but must not be over-tightened as this can damage the sealing surfaces.

In applications involving the transfer through the hose of expensive or dangerous fluids or gases, the connections must be pressure tested first before being put in to service. This should be done with some harmless media, like water or compressed air, to 1 1/2 times the maximum working pressure of the hose assembly, as defined in this brochure.

If in doubt, consult Aflex Hose for advice.

MWP of Hose*	Minimum Burst Pressure	Maximum Continuous Hose Length	Weight per Unit Length
Bar	Bar	Mtrs	Kg/Mtr
5	20	20	.06
80	320	20	.14
80	320	18	.22
5	20	20	.15
70	280	20	.29
35	140	20	.22
70	280	18	.39
70	280	18	.39
10	40	20	.19
5	20	20	.17
65	260	20	.35
33	130	20	.25
65	260	18	.47
65	260	18	.47
10	40	20	.20
5	20	20	.20
60	240	20	.40
30	120	20	.28
60	240	18	.55
60	240	18	.55
10	40	20	.24
4	16	20	.28
55	220	20	.52
27.5	110	20	.38
55	220	18	.74
55	220	18	.74
10	40	20	.33
4	16	20	.36
50	200	20	.63
25	100	20	.47
50	200	18	.92
50	200	18	.92
10	30	20	.41
3	12	20	.45
45	180	20	.85
23	90	20	.72
45	180	18	1.15
45	180	18	1.15
6	24	20	.53
2	8	18	.54
40	160	18	1.00
20	80	18	.86
40	160	16	1.38
40	160	16	1.38
6	20	18	.68
2	8	17	.66
40	160	17	1.10
20	80	17	.90
40	160	15	1.55
40	160	15	1.55
6	20	17	.78
2	8	13	.82
35	140	13	1.38
18	72	13	1.12
35	140	11	1.94
35	140	11	1.94
6	16	13	.97
2	8	10	1.25
30	120	10	1.90
15	60	10	1.60
30	120	8	2.56
30	120	8	2.56
6	12	10	1.42

*MWP: the Maximum Working Pressure of a hose assembly is limited to the lowest of the MWPs of either of the two end fittings, as given for each end fitting design on pages 15-22, or of the hose itself as listed above.

Bioflex Hose Liners

GP - General Purpose Liner

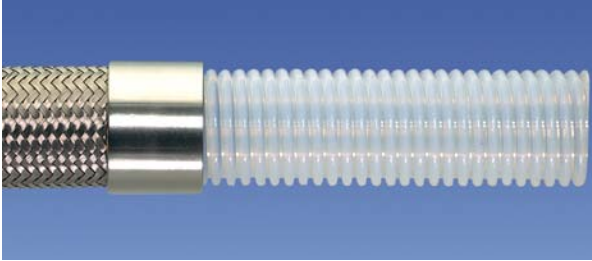

Purpose

Bioflex GP is the 'General Purpose' grade, for use in all applications where fluids or gases are being conveyed which do not generate a risk of static charge development (see "AS").

Design & Approvals

Bioflex GP is a virgin PTFE liner, manufactured from hose grade PTFE which conforms to the requirements of:

FDA 21 CFR 177.1550

Bioflex GP hose liner tube has also been tested, and complies with:

USP Class 6 :

- Systemic Injection Test
- Intracutaneous Test
- Intramuscular Test
- USP L929 MEM Elution Test (Cytotoxicity)

EC - ELECTRICAL CONTINUITY

When EC grade is requested, whether the hose liner is GP grade or AS grade, it requires that the hose assembly supplied is electrically continuous, or conductive, between metal end fittings at each end of the hose.

The requirements for this are specified in the German Document BRG132, and the Specification EN ISO 12115, tested to EN ISO 8031 Clause 3.7, which requires that for hose assemblies with a resistance between fittings of $\leq 10^2$ ohms, a letter "M" can be applied, or $\leq 10^6$ ohms, a letter "Ω" can be applied.

Braided Bioflex Hose Assemblies all meet the requirements of both "M" and "Ω", but are not stamped unless requested.

The only exception is for assemblies without braid. Grade AS, TO (Antistatic, Tube Only) meets the requirements of "Ω", $< 10^6$ ohms, but Grade GP, TO (Natural, Tube Only) does not meet either "M" or "Ω".

AS - Anti-Static PTFE Liner

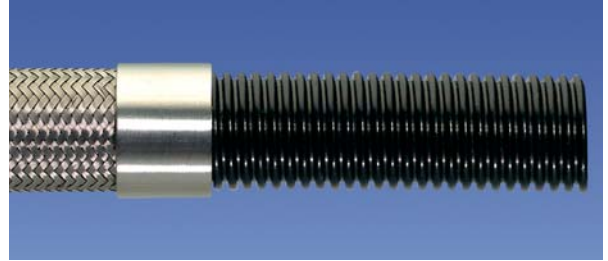

Purpose

Bioflex AS is an essential requirement in applications where there is the risk of an electrostatic charge build-up on the inside surface of the PTFE tube which may then discharge through the tube wall. Media passing through which create such a risk are fluids which have a Conductance of less than 10^{-8} S/m (Siemens per Metre), or 10^4 pS/m such as fuels, solvents, freons, some WFI (ultra-pure "Water for Injection") and non-polar organics which are being transferred at a medium to high flow velocity.

All twin or multi phase media, and any non-mixing media, such as powder in air, or water droplets in steam, in gases or in oil, also colloidal fluids constitute a particular hazard for static charge generation, and always require grade AS.

If in doubt, consult Aflex Hose.

Design & Approval

Bioflex AS is an anti-static PTFE liner manufactured from FDA approved PTFE, and less than 2.5% of "high purity" Carbon Black material to FDA requirement 21 CFR 178.3297. The carbon is encapsulated by the PTFE, and in normal, non-abrasive applications will not come loose to contaminate any fluid passing through. Bioflex AS also conforms to:

USP Class 6 :

- Systemic Injection Test
- Intracutaneous Test
- Intramuscular Test
- USP L929 MEM Elution Test (Cytotoxicity)

Specifications

When "AS" (Antistatic) grade hose is specified, then the hose supplied will be in accordance with the requirements of BS5958 Part 2, 1991 Clause 19.3, when tested in accordance with EN ISO 8031 Clause 3.1, which requires that the resistance between a plug inserted 25mm into the bore at the end of the hose assembly, and one of the metallic end fittings should be less than 10^8 ohms.

NOTE: When in service, at least one end fitting must be connected to earth, to permit dissipation of the static charge from the end fitting.

Bioflex Hose Braids

SS - Stainless Steel Braid

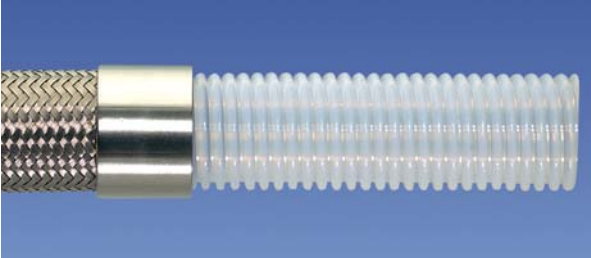

Purpose

Stainless Steel braided hose is the general purpose product, and can be used in applications involving high temperatures and working pressures. High tensile AISI 304 stainless steel wire is used, to give maximum pressure resistance and external protection to the hose.

PB - Polypropylene Braid

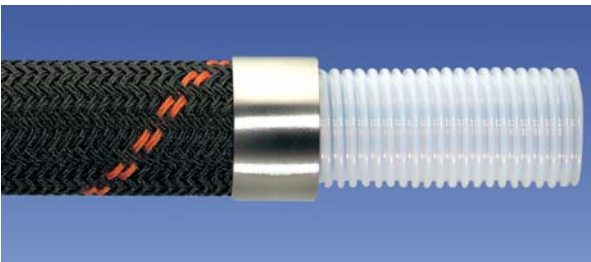

Purpose

Polypropylene braided hose is often preferred to SS in applications involving frequent handling and movement of the hose, and where temperatures are within the range -30°C and +100°C. PB braid is lighter in weight, and any broken strands will not cut the operator's hands. In addition, PB braid is not prone to "chloride stress corrosion", and has generally good chemical resistance.

NOTE: Prolonged exposure to sunlight eventually results in UV degradation of PB braid.

KYB - Kynar Braid (Polyvinylidene Fluoride Monofilament)

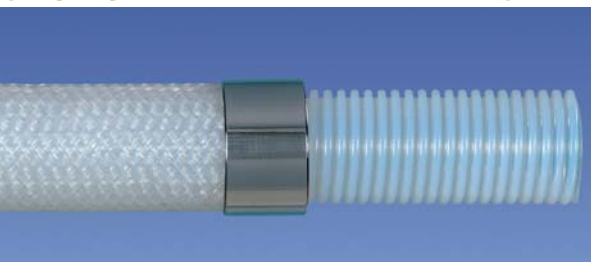

Purpose

Kynar Braid is used for the same reasons as HB above, but only in applications where the reduced pressure and temperature ratings of KYB are acceptable.

TO - Tube Only (no braid)

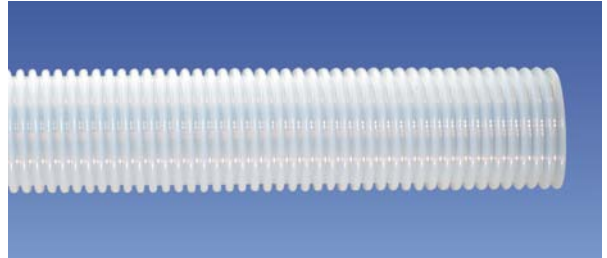

Purpose

TO grade hose (available in both GP and AS) is a lightweight hose, used in applications where working pressures are low and where there is no need for the physical protection offered by an external braid. TO grade is not vacuum-proof.

TO grade tube is not normally helium tested.

HB - Hastelloy Braid (C276 grade)

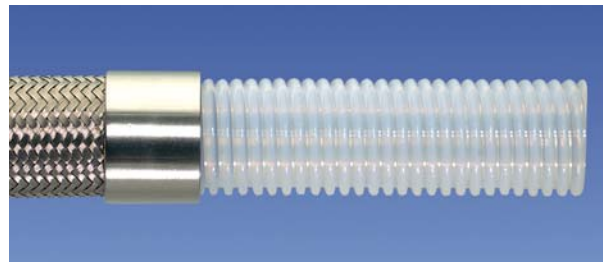

Purpose

Hastelloy Wire Braid is used instead of SS where severe chemical corrosion conditions exist around the outside of the hose. One way in which this can happen is when Chlorine or Fluorine are being transferred. Diffusion of trace quantities of such gases through the PTFE liner can lead to atmospherically wetted fluorine or chlorine attacking the braid material, in which case the Hastelloy Braid would be resistant.

Specifications

Same as for SS on Pages 9 and 10, except the Burst Pressures and the Maximum Working Pressures are both reduced to 50% of the SS pressures listed.

Also, the sizes range is restricted, from 1/2" up to 2" bore only.

Bioflex Rubber Covers

RC - Rubber Covered



Purpose

For the most rugged applications where the hose may be subjected to rough treatment and severe external abrasion. Also for hygienic applications, where the external smoothness and cleanability of the hose is of prime importance.

Design

An SS braided hose assembly has a smooth finish, blue EPDM external rubber cover vulcanised directly onto the braid. EPDM has excellent chemical resistance, and is temperature resistant up to 120°C (external) 140°C (internal). Black anti-static EPDM, and alternative colours of rubber, and strips with alternative text titles are available to special order.

Specifications

The EPDM rubber cover has been tested and conforms to the requirements of USP Class VI.

SI - Silicone Rubber Cover

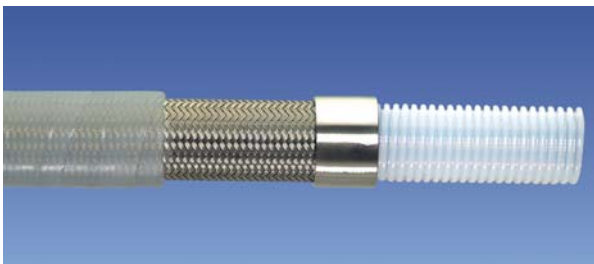

Purpose

As for RC hose, but where the hose may be required to withstand temperatures up to 180°C. SI grade hose is semi-transparent, allowing visual monitoring of the braid.

Design

An SS braided hose assembly has an external smooth finish silicone rubber cover vulcanised directly onto the braid.

Specifications

The Silicone rubber cover has been tested and conforms to the requirements of USP Class VI.

FP - Fireproof Rubber Covered



Purpose

As for RC hose, but where the hose is also required to resist failure in the event of fire, in accordance with Specification BS5173 Section 103.13 (Fireproof). This specification calls for an 1100°C flame to be applied to the hose at minimum bend radius, maximum operating pressure (water), and one end fitting under vibration. The hose must withstand at least 15 minutes without leakage.

Design

As for RC hose, but the red EPDM rubber is specially compounded to be fire resistant. Black, anti-static EPDM Fireproof rubber is also available as an option to special

RC-300 - Rubber Covered 300mm at End



Purpose

In applications where excessive flexing of the hose at the end fitting occurs, it is sometimes necessary to 'stiffen' the hose in this area, to prevent kinking.

Design

A layer of rubber is applied and vulcanised directly to the ferrule, and 300mm along the hose from the fitting. This can be done either on an SS braided hose (RC-300) or on a rubber covered hose as a 300mm long double layer of rubber at the end (DRC-300).

The rubber used is normally Blue EPDM, but if the hose is FP, or SI covered, then the same type and colour of rubber would be used (DFP-300 or DSI-300).

Limitations

Cannot be applied to PB or KYB braided hose. If required consult Aflex Hose for an alternative "EPR" system. (EPR includes a 300mm length of loose rubber hose jubilee clipped to the ferrule).

Bioflex External Protection Systems

KR - Kink Resistant



Purpose

For applications where there is a risk that the hose might be severely flexed anywhere along its length, and possibly kinked as a result.

Design

KR is only available on hoses which also have a SS wire braid and a rubber cover (RC, FP or SI). An SS reinforcement wire is helically wound on to the SS wire braid, then the rubber cover is applied on top of the helical wire.

Limitations

Only available for sizes $\frac{3}{4}$ " and above.

Specifications

As per the Rubber Covered hose grade, except that the standard RC Grade rubber has a super-smooth finish which is not possible on the "KR" hose grade.

SR - Scuff Rings



Purpose

For medium duty applications where the hose requires some protection against abrasion when dragged over the ground, but where a full rubber cover would be too heavy and cumbersome. Also for PB and KYB braided hose, which cannot be Rubber Covered.

Design

Specially moulded abrasion resistant rubber scuff rings are placed every half metre along the hose.

Limitations

Available for hose sizes 1" (25mm) to 2" (50mm) only. The operating temperature should not exceed 140°C (internal).

PC - Protection Coil

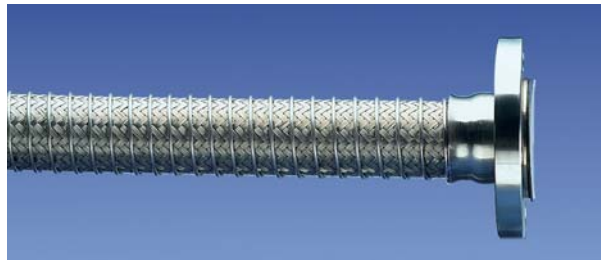

Purpose

For applications where the hose requires protection against abrasion when dragged over the ground, but where any rubber reinforcement is not permissible due to temperature, chemicals etc.

Design

A stainless steel wire helix is wound onto the braid and welded to the ferrules at each end.

Limitations

Only available on SS, PB, HB or KYB in sizes of $\frac{3}{4}$ " and above.

Specifications

As for the Braided Hose Grade.

Bioflex Standard Flange Fittings

Flange Fittings

Description

Swivel flange fitting, integral PTFE lined and flared.

Specifications

Flanges to ASA 150 (ASME B16.5 Class 150), DIN PN10 or PN16, and BS10 Table E. Other flange ratings to these specifications are also available, and other types of flanges can be supplied.

Materials

Grade 316 SS Spigot, Grade 304 Flange and Ferrule, except 1", 1 1/2" and 2" PN10 Flanges are Grade 316. Alternative options include grade 316 SS flanges, polypropylene flanges mounted on SS spigots, zinc or nickel plated mild steel flanges, and other materials to special order.

Maximum Working Pressures

These are defined by the flange specification. For standard PN10 and PN40 etc. the Maximum Working Pressures are 10 Bar and 40 Bar respectively. For ASA 150 the Maximum Working Pressure is 230 psi or 16 Bar. Test Pressures are 1.5 times the MWP of the fitting. (Exceptions: when the hose MWP is less than the fitting MWP).



Standard Flange Fitting

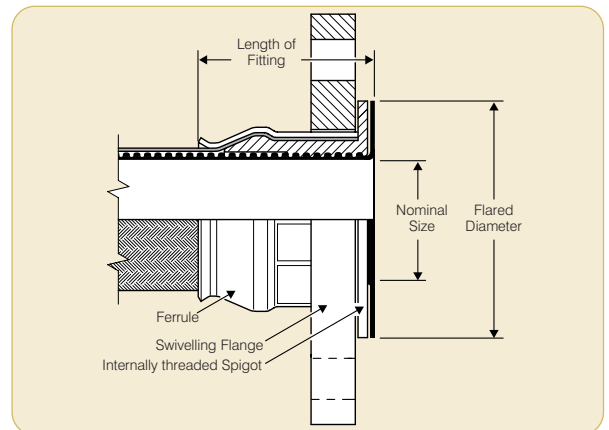

Hose Size		Nominal Size of - Flange		Fitting Length		Flared Diameter				Recommended Bolt Tightening Torques		Weight/ Fitting
in	mm	in	mm	in	mm	ASA 150		DIN PN10		ft. lbs	mtr. kgs	kg
						in	mm	in	mm			
1/2	15	1/2	15	1 1/16	37.0	1 1/4	32	1 1/4	32	8	1.10	0.54
1	25	1	25	1 5/8	40.5	2	50	2 1/2	63	10	1.40	0.96
1 1/4	32	1 1/4	32	1 11/16	43.5	2 1/2	63	3	78	12	1.70	1.36
1 1/2	40	1 1/2	40	1 7/8	47.0	2 7/8	73	3 1/2	88	15	2.10	1.75
2	50	2	50	1 15/16	48.5	3 5/8	92	4	102	25	3.50	2.70
*2	50											
*2	50	3	80	3 1/2	89.0	5	127	5	127	40	5.60	5.20

These are not the correct flared diameters, but they are the maximum diameter to which the PTFE can be flared out for that flange size. If the full size flare diameter is required, consult Aflex Hose for a solution.

**"Step-Up" Flange Fittings on 2" Hose (see list)

Because the 2" Bioflex Hose has better flow rates than both 2 1/2" and 3" Convoluted PTFE hose, it represents a superior alternative when fitted with the larger flanges.

It is, however, necessary to also "Step-Up" the PTFE-lined bore, to ensure an diameter match with the mating connector.

This is best achieved using a solid PTFE Adaptor Plate, as shown in the drawing.

Other sizes scan also be "Stepped Up" if required, for example 1" Hose to 2" Flange.

2" to 3" ASA150 Flange Joint

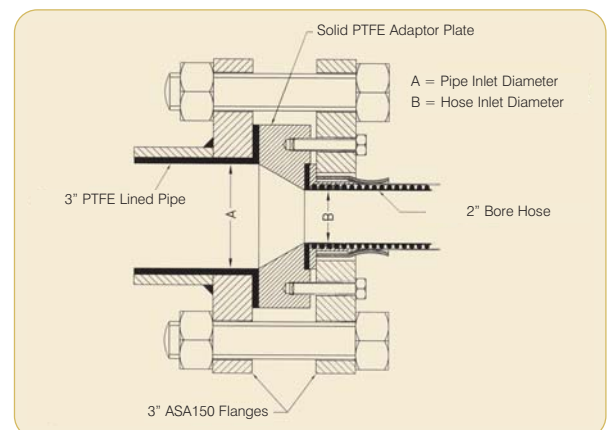

Bioflex DIN 11851 Fittings

DIN 11851 Fittings (Male & Female)

Description

DIN 11851 male and female fittings, integral PTFE lined and flared.

The PTFE sealing face is hot moulded into the correct shape, designed to achieve the optimum pressure seal.

Specification

Generally to German DIN 11851 specifications.

NB: The PTFE lined male fitting is designed to be used without a rubber seal. Please note that when connecting to a PTFE Lined DIN11851 Male, extra spanner tightening of the nut is sometimes required in order to provide a leak free connection.

Materials

Spigots in Grade 316 SS nuts and ferrules in Grade 304 SS.

Maximum Working Pressures (MWP)

SS Braided, $\frac{3}{4}$ " to $1\frac{1}{4}$ " MWP = 40 Bar.

$1\frac{1}{2}$ " and 2" MWP = 25 Bar.

PB Braided, MWP as for hose.

Test Pressure = 1.5 x MWP.

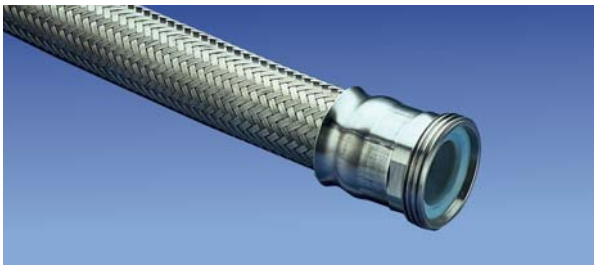

DIN11851 Male Fitting

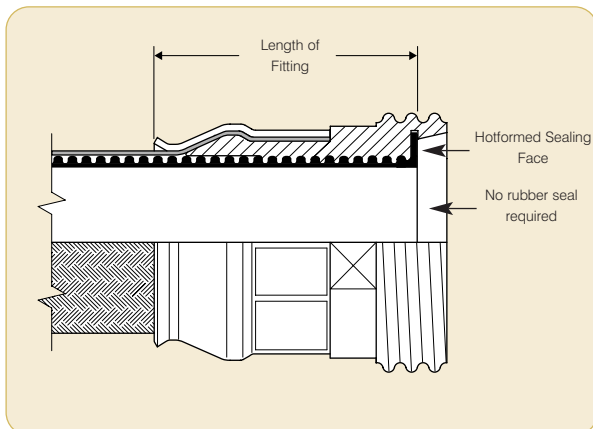

DIN11851 Female Fitting

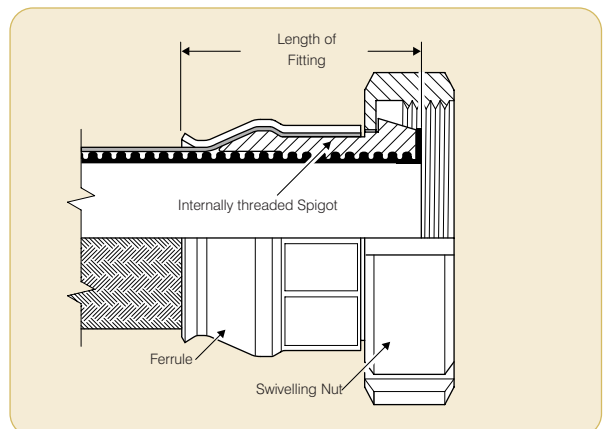

Nominal Size		Fitting Length (Male) (non rubber covered grades only)		Fitting Length (Female) (non rubber covered grades only)		Weight of Fitting	
Hose in	Fitting DN	in	mm	in	mm	Male kg	Female kg
$\frac{1}{2}$	15	$1\frac{7}{8}$	48.5	$1\frac{5}{8}$	41.5	0.13	0.16
$\frac{3}{4}$	20	2	50.5	$1\frac{3}{4}$	44.0	0.18	0.22
1	25	$2\frac{1}{8}$	54.5	$1\frac{15}{16}$	49.0	0.22	0.36
$1\frac{1}{4}$	32	$2\frac{3}{16}$	55.5	2	51.0	0.27	0.47
$1\frac{1}{2}$	40	$2\frac{1}{4}$	58.0	$2\frac{1}{2}$	63.5	0.33	0.55
2	50	$2\frac{3}{8}$	66.0	$2\frac{1}{2}$	64.0	0.58	0.93

Bioflex Saflok Cam Action Fittings (Fixed or Swivel)

Saflok Cam Action Coupler Fittings

Description

PTFE Lined Fixed or Swivelling Auto-Locking Arm Cam Action Quick Release Fitting. The lock is released by pulling a wire ring horizontally away from the fitting, then using the ring to pull the arm open. The lock is designed as a safety feature, to prevent accidental opening of the connection resulting from vibration or "tugging".

Specifications

Generally to Mil-C-27487 and DIN2828. (Fully interchangeable with other makes of Cam Action type quick-release fittings to these specifications).

Materials

Cam Action spigot in Grade 316 SS, ferrule in Grade 304 SS, standard gasket in buna N nitrile rubber, with alternatives available.

Alternative Gasket Materials

FEP-encapsulated Silicone Rubber Gasket. (Rubber fully encapsulated inside an FEP outer). Usable at temperatures up to 160°C. (Note: this type of gasket requires higher clamping forces than normal to ensure a positive seal. Normally supplied with an aluminium or polypropylene male adaptor clamped in, to "pre-set" the gasket for easier use).

NOTE: If customers want to use their own gaskets, which are not supplied by Aflex, they must supply these gaskets with their order, so that Aflex can fit these gaskets, then test the hose assemblies before despatch.

Limitations

Usable at temperatures up to 100°C, but higher temperature use is possible, dependent upon the gasket materials.

Mating Connectors

A wide variety of mating connectors is available, including BSP female threaded adaptors and PTFE lined flange adaptors.

Maximum Working Pressures

All sizes 10 Bar (Test Pressure = 15 Bar).
Higher Working Pressures up to 18 Bar are available to special order.

Cam Action Adaptor to Flange Connectors

Description & Purpose

SS Cam Action Adaptor (male) to Flange Connector, PTFE lined right through the connector.

Construction & Materials

The SS Cam Action Adaptor and Flange components are welded together, and include a thick wall PTFE liner, either GP or AS grade, flared at both ends.

Cam Action Adaptor Size		Flange Size & Specification	Flare Dia. on Flange		Length		Minimum Through Bore	
in	mm		in	mm	in	mm	in	mm
1	25	1" ASA 150	2.00	50	4 ¹ / ₈	105	0.84	21
1	25	DN25/PN16	2.58	64	4 ¹ / ₈	105	0.84	21
1 ¹ / ₂	40	1 ¹ / ₂ " ASA 150	2.87	73	4 ³ / ₈	118	1.35	34
1 ¹ / ₂	40	DN40/PN16	3.47	88	4 ³ / ₈	118	1.35	34
2	50	2" ASA 150	3.63	92	4 ³ / ₈	118	1.69	43
2	50	DN50/PN16	3.63	92	4 ³ / ₈	118	1.69	43

Saflok Cam Action Fitting

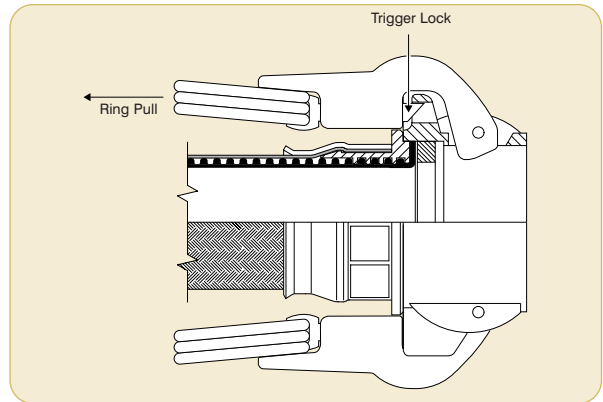

Nominal Size		Length of Fitting (non rubber covered grades only)		Weight of Fitting
in	mm	in	mm	
3/4	20	2 ¹ / ₄	57	0.42
1	25	2 ¹ / ₂	63	0.59
1 ¹ / ₂	40	2 ³ / ₄	70	1.15
2	50	2 ³ / ₄	70	1.40

Other sizes available to special order.



Cam Action Adaptor to Flange Connector

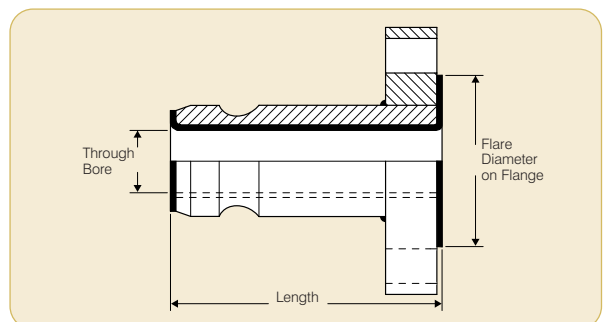

Bioflex Standard Cam Action Fittings

Cam Action Adaptor (Male) Fittings

PTFE Lined Cam Action Adaptor (Male) Fittings are also available. Specification, materials and size range as for Female (Coupler) Fittings.

Specifications

Generally to Mil-C-27487 and DIN2828. (Fully interchangeable with other makes of Cam Action type quick-release fittings to these specifications).

Materials

Cam Action spigot in Grade 316 SS, ferrule in Grade 304 SS.

Maximum Working Pressures

All sizes 10 Bar (Test Pressure = 15 Bar)

Higher working pressures up to 18 Bar are available to special order.

Cam Action Coupler (Male) Fitting

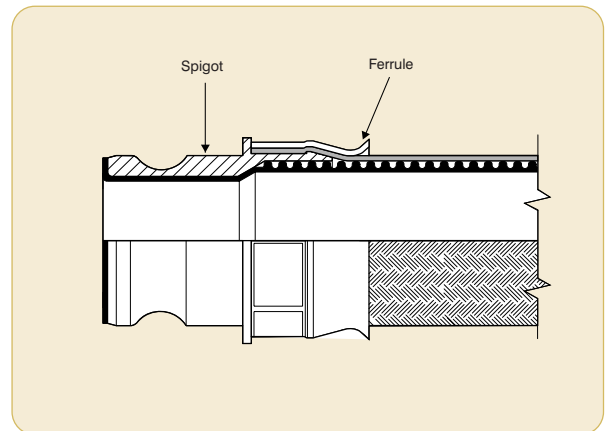

Bioflex Triclover Fittings - Not PTFE Lined

Triclover Fittings

Description

Triclover fitting, not PTFE lined. Hygienic design spigot, all internal (wetted) surfaces polished to $<0.375\mu\text{m}$ ($<15\mu$ in) and Electropolished.

Specifications

Generally in accordance with BS4825: Pt 3 or DIN 32676, also others.

Maximum Working Pressures and Temperatures

All sizes 16 Bar (Test Pressure = 24 Bar). Only up to the temperature limit of the rubber seal.

Materials

Spigot in Grade 316 S11 (AISI 316L, or 1.4404), Ferrule in Grade 304 SS.

Size of Triclover Fittings

When ordering, it is necessary to determine:

- What standard of internal polish is required?
- What Triclover Flange Diameter is required?
- What is the Hose Size required?
- Is the Outlet Diameter for the hose fitting the same as the I/D of the Pipe to which it will be connected?

See the List for the Sizes & Outlet Diameters. If the requirement is not on this list, then please specify the alternative dimensions required.

If in doubt, request a "Triclover Enquiry Form" from Aflex Hose, to be filled in and returned.

Unpolished, Non-Lined Triclover Fittings

In applications where polishing is not required, but the most economical price is required, unpolished and/or purge-welded end fittings to special order can sometimes provide a solution.

Consult Aflex for details.



Non-Lined Triclover Fitting

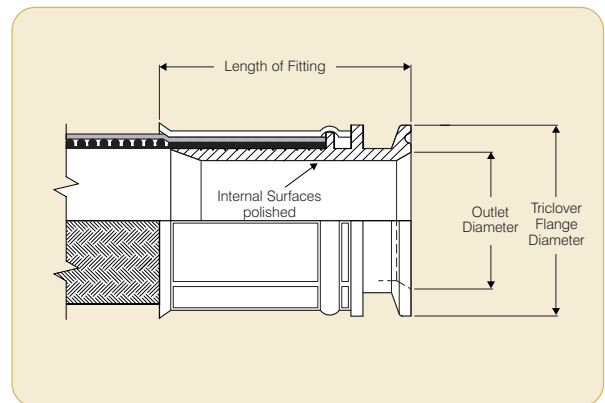

Standard Hose and Pipe Sizes, and Outlet Diameters

Nominal Hose Size	Standard Triclover Flange Dia.	Pipe I/D Equal to Fitting Outlet Diameter	Nominal Pipe Size (inches = BS4825, DN = DIN 32676)	Length of Fitting
in	mm	mm		mm
1/2"	25.0	9.5 (3/8")	1/2" & DN10	34.5
5/8"	25.0	16.0 (5/8")	3/4"	38.0
3/4"	25.0	16.0 (5/8")	3/4"	47.5
3/4"	34.0	16.0 (5/8")	DN15	47.5
1"	50.5	22.2 (7/8")	1"	47.5
1"	50.5	26.0 (1")	DN25	47.5
1 1/4"	50.5	32.0 (1 1/4")	DN32	62.5
1 1/2"	50.5	34.9	1 1/2"	66.5
1 1/2"	50.5	38.0 (1 1/2")	DN40	66.5
2"	64.0	47.6	2"	69.8
2"	64.0	50.0	DN50	69.8
2"	77.5	60.3	2 1/2"	76.0
2"	91.0	66.0	DN65	76.0
2"	91.0	73.0	3"	76.0
2"	106.0	81.0	DN80	76.0
2"	119.0	97.6	4"	86.0
2"	119.0	100.0	DN100	84.5

= Standard, stocked fittings - the other sizes are available to special order.

Bioflex Triclover Fittings - PTFE Lined

Triclover Fittings

Description

Triclover fitting integral PTFE lined and hot formed. Design patented in Europe by Aflex Hose Ltd.

Specifications

Generally in accordance with BS4825: Pt 3, or DIN 32676.

Maximum Working Pressures and Temperatures

All sizes 16 Bar. (Test Pressure = 24 Bar). Only up to the temperature limit of the rubber seal.

Materials

Spigots Grade 316 SS. Ferrules Grade 304 SS.

Size of Triclover Fittings

When ordering, it is necessary to determine:

- What Flange Diameter is required?
- What is the Hose Size required?
- Is the Outlet Diameter for the hose fitting the same as the I/D of the Pipe to which it will be connected?

See the List for the Standard Sizes & Outlet Diameters. If the requirement is not on this list, then please specify the alternative dimensions required.

If in doubt, request a "Triclover Enquiry Form" from Aflex Hose, to be filled in and returned.



PTFE Lined Triclover Fitting

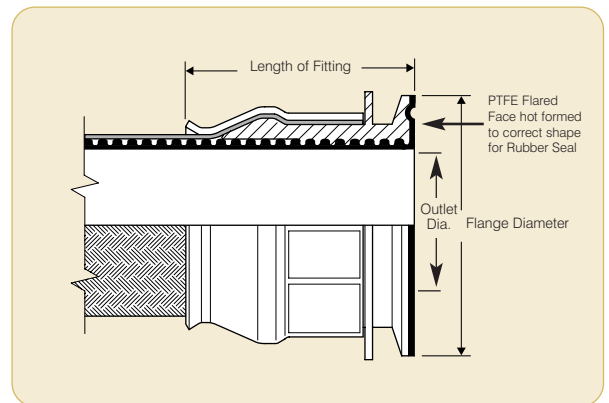

Standard Hose and Pipe Sizes, and Outlet Diameters

Nominal Hose Size		Standard Triclover Flange Dia.	Pipe I/D Equal to Fitting Outlet Diameter	Nominal Pipe Size (Inches = BS4825, DN = DIN 32676)	Specs & Sizes with pipe I/D which are larger than the largest O/D possible with a lined end from the hose size shown. Set against the nearest option	Length of Fitting (non rubber covered grades only)
in	mm	mm	mm			mm
3/8"	10	25.4	9.5 (3/8")	1/2"		53.0
3/8"	10	34.0	10.0	DN10		53.0
5/8"	16	34.0	16.0 (5/8")	DN15		55.0
7/8"	22	50.5	22.2 (7/8")	1"		53.0
1"	25	50.5	26.0 (1")	DN25		51.0
1 1/4"	32	50.5	32.0 (1 1/4")	DN32		56.0
1 3/8"	35	50.5	34.9 (1 3/8")	1 1/2"	DN40 (38mm Pipe I/D)	56.5
1 7/8"	48	64.0	47.6 (1 7/8")	2"	DN50 (50mm Pipe I/D)	58.0
*2"	50	77.5	*60.3 (2 3/8")	2 1/2"		69.0
*2"	50	91.0	*66.0	DN65		74.0
*2"	50	91.0	*73.0 (2 7/8")	3"		87.0
*2"	50	106.0	*81.0	DN80		111.0

Note: The 3/8", 5/8", 7/8", 1 3/8" and 1 7/8" hose sizes can only be supplied as assemblies with lined triclovers (or I-Lined fittings) at BOTH ends, because other types of fittings (flanges, camlocks etc.) are not available for these hose sizes.

*"Step Up" PTFE Lined Triclover Fittings

Because the 2" Bioflex Hose has better flow rates than either 2 1/2" or 3" convoluted PTFE hose, it represents a superior alternative when fitted with larger Triclover fittings.

It is, however, necessary to "Step Up" the PTFE lined bore, to ensure a diameter match between the Outlet Diameter and the Pipe I/D, as shown in the drawing.

* "Step Up" PTFE Lined Triclover Fitting

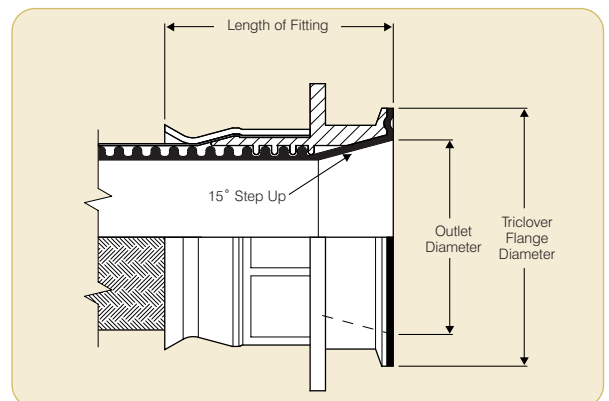

Bioflex “PTFE Beaded” Triclover Fittings

Description

In this new (patent pending) design, the PTFE hose liner tube is extended through the Triclover end fitting, and is flared over the sealing face. It is then hot-formed to conform to the shape of the rubber seal, and therefore replaces the rubber seal.

This includes the ‘bead’ shape, which is used for concentric location of the seal to the mating component when a joint is made, as shown in the sketch opposite.

Advantages of the Bioflex PTFE Beaded End Fitting

- After connection, the PTFE does not ‘bulge’ into the bore in the same way that a rubber seal would. This rubber ‘bulge’ interferes with the flow path, and can cause material entrapment, but these problems are eliminated by using this new design.
- The need to ensure the compatibility of the rubber seal with the media passing through is no longer a problem, due to the all-PTFE sealing system.
- The joint includes only one sealing face, not 2 as with the rubber seal.
- The internal section of the moulded PTFE seal, which is squared off to provide a closed sealing edge in the joint, ensures no crevices in which materials entrapment might occur.
- **REPAIR NOTE** - If the PTFE sealing face is damaged by being dented, but is not actually cut open, then **it can be repaired**, by reheating and reforming the sealing face. This can be done by Aflex Hose for a small charge.
- If hoses are required to be joined together, then the Bioflex PTFE Beaded Triclover End Fitting can be connected to a standard Bioflex Triclover Fitting (see page 19) to provide an all-PTFE lined joint between the hoses.

Specifications

Generally in accordance with BS4825:Pt 3 or DIN 32676, also others to special order.

Materials

Spigot in Grade 316 SS. Ferrules in Grade 304 SS.

Maximum Working Pressures

All sizes 16 Bar (Test Pressure 24 Bar). Only up to 130°C.



Bioflex PTFE Beaded Triclover End Fitting
(Shown in a joint with a Triclover Pipe Connection)

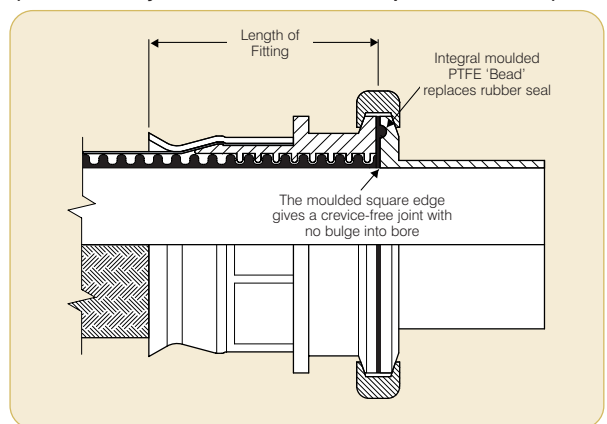

Standard Hose and Pipe Sizes, and Outlet Diameters

Nominal Hose Size		Standard Triclover Dia.	Pipe I/D Equal to Fitting Outlet Dia.	Nominal Pipe Size (inches = BS4825, DN = DIN 32676)	Length of Fitting (non rubber covered grades)
in	mm	mm	mm		
3/4"	20	34.0	19/20	DN20	50.8
7/8"	22	50.5	22	1"	56.6
1"	25.4	50.5	26	DN25	52.6
1 3/8"	35	50.5	34.9	1 1/2"	60.0
1 7/8"	48	64.0	47.6	2"	62.6

Bioflex SMS & RJT Fittings

SMS Female Fittings

Description

SMS female fitting, integral PTFE lined.

Flared Face "Hotformed" into correct shape for seal.

Specification

Generally to Swedish SMS 1148 specification.

Materials

Spigot Grade 316, Ferrule & Nut Grade 304.

Maximum Working Pressures

All sizes 10 Bar. (Test Pressure = 15 Bar).

Nominal Size		Length of Fitting (non rubber covered grades only)		Weight of Fitting
in	mm	in	mm	kg
1	25	2 ¹ / ₂	66	0.25
1 ¹ / ₄	32	2 ⁵ / ₈	72	0.36
1 ¹ / ₂	40	2 ³ / ₄	81	0.46
2	50	2 ³ / ₄	79	0.64

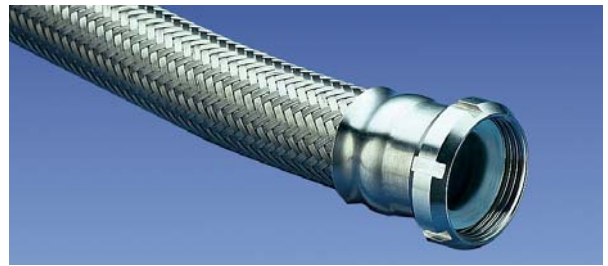

SMS Female Fitting

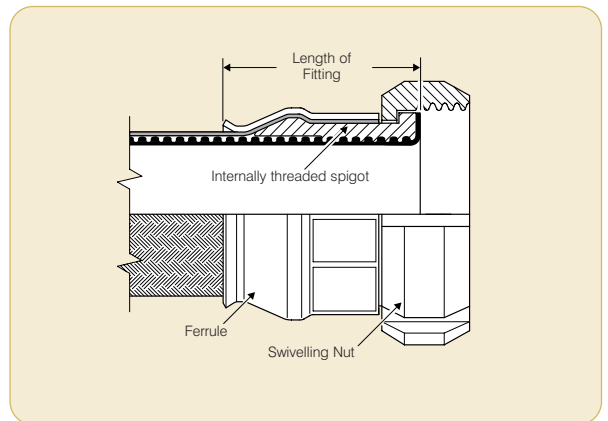

RJT Female Fittings

Description

RJT female fitting, integral PTFE lined.

Flared Face "Hotformed" into correct shape for seal.

Specification

Generally to BS4825: Pt 5.

Materials

Spigot Grade 316, Ferrule & Nut Grade 304.

Maximum Working Pressures

All sizes 10 Bar. (Test Pressure = 15 Bar).

Nominal Size		Length		Weight of Fitting
in	mm	in	mm	kg
1	25	2 ¹ / ₂	68	0.25
1 ¹ / ₂	40	2 ³ / ₄	73	0.46
2	50	2 ³ / ₄	76	0.64

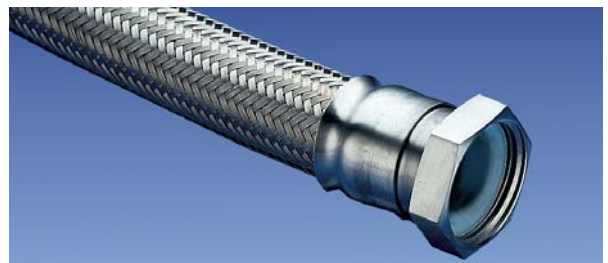

RJT Female Fitting

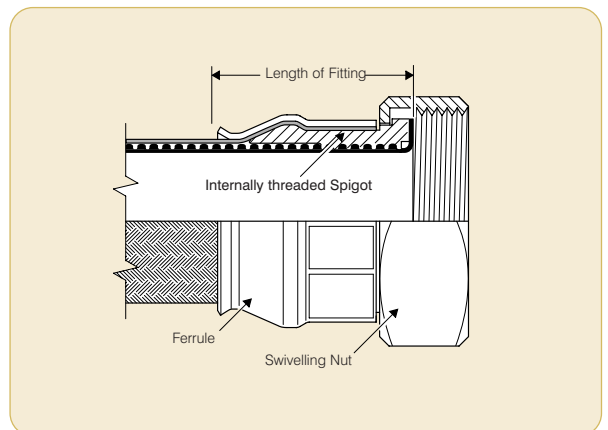

Bioflex 90° Elbow Fittings

Introduction

In applications where the hose is normally used at 90° to an end fitting, for example when a hose length is hanging vertically downwards from a horizontal connection, to pipework, then a 90° elbow can be used to "take the strain".

PTFE Lined 90° Elbow End Fittings

As with most end fittings for Process Fluid applications, it is usually preferred that elbows are PTFE lined, for cleanliness, and to avoid internal bacteria traps.

Aflex have developed a new design of PTFE lined 90° elbow. This design includes a normal PTFE lined straight fitting, attached to the end of the hose. The hose behind the fitting is passed through a 90° elbow stainless steel tube, which is welded to the back of the ferrule, as shown opposite.

Size Range & Specification

Triclover Fittings: Hose Sizes 7/8", 1", 1 3/8", 1 7/8" & 2" only. With all Other Fittings: Hose Sizes 1", 1 1/2" & 2" only.

Limitations

Specifications are generally the same as for the hose and straight end fittings.

Elbows for Stainless Steel Braid and Rubber Covered Grades are available, but not for PB & KYB Braids.

Minimum Hose Lengths with 1 x Elbow Fittings:

7/8" & 1" = 300mm 1 3/8", 1 1/2", 1 7/8" & 2" = 500mm. (Double for 2 elbow fittings)

Dog-Legs

Elbow pieces can also be used to create 'dog-legs' in hoses, to shape the hose in applications where this may be an advantage, to special order.

(Only available for the hose sizes as above, but not for the rubber covered grades, and not for PB and KYB grades).

Non-Lined 90° Elbow End Fittings

A 90° elbow attached to the hose can be supplied non-PTFE lined, as shown, for any size of hose or type of fittings, to special order.

PTFE Lined 90° Elbow End Fitting

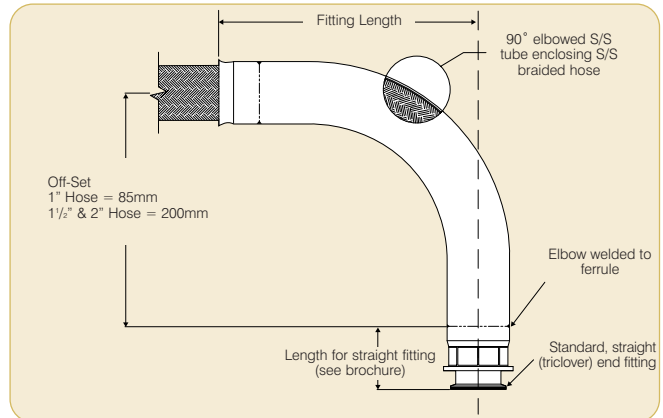

Hose Bore Sizes	Off-Set	Fitting Length
	mm	mm
7/8" or 1"	85	143
1 3/8", 1 1/2"	200	237
1 7/8" & 2"	200	314

Dog-Legs

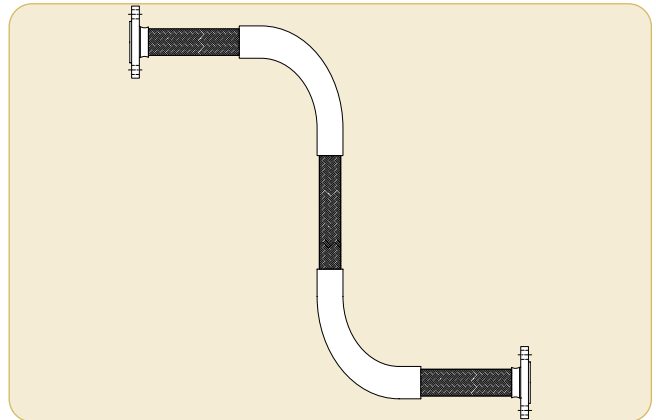

Non-Lined 90° Elbow

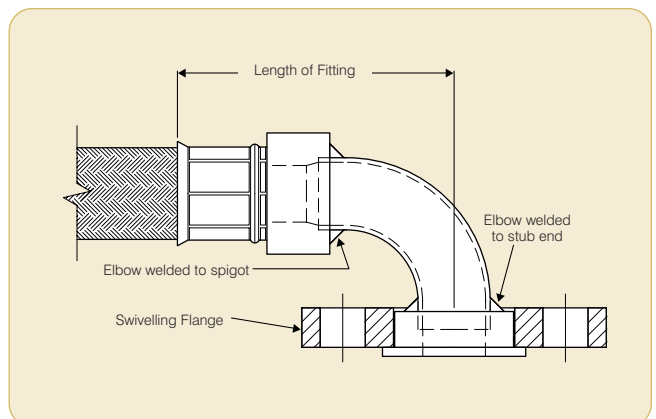

Bioflex I-Line Fittings

PTFE Lined I-Line Fittings

I-Line fittings, Integral PTFE Lined and Flared. Designed to be used together with the standard clamps and Gaskets (EPDM, Nitrile, Viton, PTFE).

Maximum Working Pressures

All sizes up to 18 Bar (Test Pressure = 27 Bar).

Materials

Spigots Grade 316, Ferrule Grade 304.

Nominal Hose Size		I-Line Fitting Size		Sleeve Diameter		Fitting Length
in	mm	in	mm	in	mm	
7/8"	22	1	25	1 1/4"	31.88	57.90
1 3/8"	35	1 1/2"	40	1 3/4"	44.58	57.90
1 7/8"	48	2"	50	2 1/4"	57.40	66.70

Limitations

Like PTFE-Lined Triclovers, I-Line fittings are used on 7/8", 1 3/8" and 1 7/8" hose sizes, with only the possibility of I-Line or Triclover fittings at the other end.

Adaptors

PTFE-Lined and Flared Flange-to-I-Line adaptors are also available, to special order.



I-Line Female Fitting

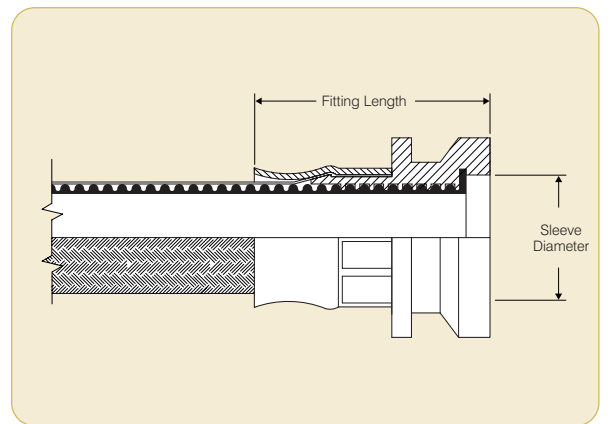

I-Line Male Fitting

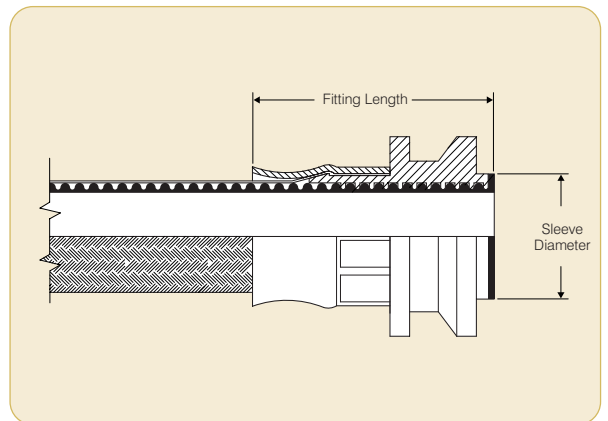

Bioflex Dip Pipes

Fixed Dip Pipes

Description

Fixed Dip Pipes are rigid tubes, either straight or 90° elbowed, which are directly crimped to the end of Bioflex hoses. They are designed for insertion into drums, tanks and reaction vessels in order to suction drain (or inject) process fluids transferred through the hose.

Materials

Standard dip pipes are in anti-static (AS) PTFE. Also available in 316 SS, polypropylene, virgin PTFE (GP) and other materials to special order.

How to order

Specify the size and material of the dip pipe, whether it is straight or 90° elbowed. Give the length of the straight leg of the dip pipe and the length of the rest of the hose assembly separately.

Maximum Working Pressures

Dip Pipes are normally only tested to 4 Bar Pressure, and are not suitable for use at pressures higher than 3 Bar. They are usable at negative pressure up to full vacuum.

If higher pressure ratings are required, consult Aflex Hose.

Lengths

Dip Pipes are supplied as standard in 1 metre lengths, but can be supplied in any length to individual requirements.



Nominal Hose Bore Size		Inside Diameter			
in	mm	in	mm	in	mm
1/2	15	0.63	16	0.31	8
3/4	20	0.87	22	0.51	13
1	25	1.14	29	0.83	21
1 1/2	40	1.54	39	1.00	27
2	50	2.17	55	1.58	40

Fixed Dip Pipe

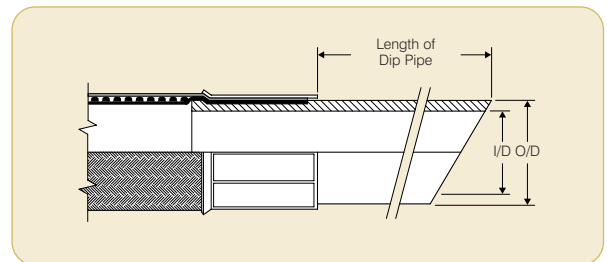

Detachable Dip Pipes

Description

As Fixed Dip Pipes above, but connected to the hose through an end fitting, not by crimping direct to the hose.

Design

A straight, or 90° elbowed anti-static PTFE Dip Pipe, fitted with (any) PTFE Lined & Flared end fitting.

The most usual end fitting is a Cam Male (as shown), so the dip pipe can then be connected to a hose with a Cam Female end fitting.

Specifications

As above for Fixed Dip Pipes.

Detachable Dip Pipe

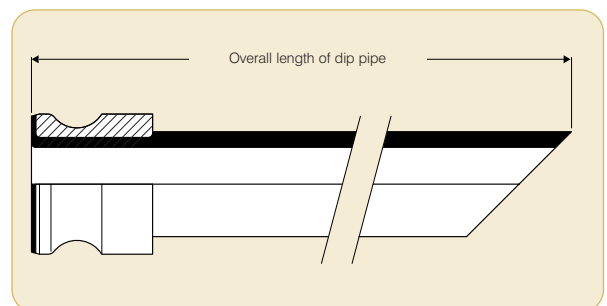

Bioflex Non Lined End Fittings

Fixed Male Fittings

Description

Fixed male fitting, BSP taper male thread.

Specifications

Threads to BS21.

Materials

All components are either zinc plated mild steel or Grade 316 SS with a Grade 304 ferrule.

Alternatives (to special order)

NPT, JIC, metric or BSP parallel screwthreads with flat face or 60° internal cone.

Polypropylene males available to special order.

Limitations

Polypropylene Fixed Male Fittings are only usable between -10°C and +50°C, and the Maximum Working Pressure is 80% less.

Maximum Working Pressures (MWP)

As given for the hose. (Test Pressures = MWP x 1.5).

Fixed Male Fitting

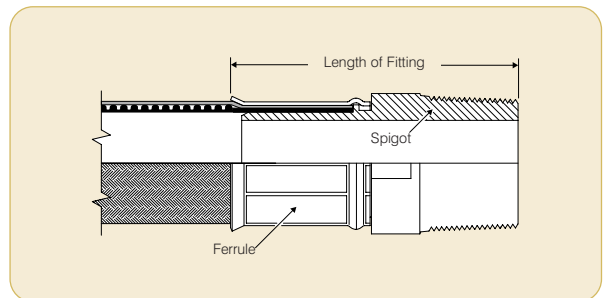

Nominal Size		Length		Weight of Fitting (steel) kg
in	mm	in	mm	
3/8	10	2 1/4	57	0.07
1/2	15	2	51	0.10
3/4	20	2 1/2	62	0.16
1	25	2 5/8	66	0.26
1 1/4	32	3 1/2	87	0.40
1 1/2	40	4	100	0.58
2	50	4 1/4	108	0.95

Cone Seat Female Fittings

Description

60° cone seat female union fitting, BSP parallel thread non-lined.

Specifications

Generally to BS5200 and ISO 1179.

Materials

All components are either zinc plated mild steel or Grade 316 SS with an Grade 304 Ferrule.

Alternatives (to special order)

These fittings may be supplied with a flat seat or with a metric or NPSM thread. Lug Nut female union (and male) fittings are also available in gun metal or stainless steel. JIC Females can also be supplied. 45° and 90° elbowed fittings also possible.

Maximum Working Pressures

As given for the hose. (Test Pressures = MWP x 1.5).

Cone Seat Female Fitting

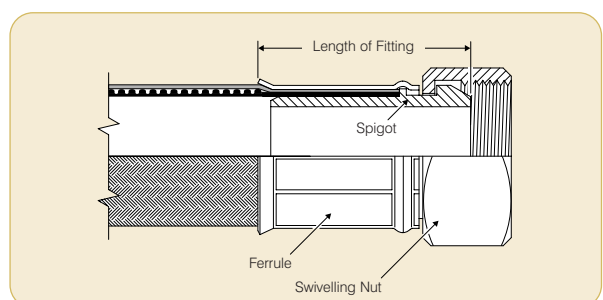

Nominal Size		Length		Weight of Fitting kg
in	mm	in	mm	
3/8	10	2	50	0.06
1/2	15	2	49	0.08
3/4	20	2 3/8	60	0.18
1	25	2 1/2	63	0.32
1 1/4	32	2 5/8	54	0.50
1 1/2	40	2 5/8	54	0.58
2	50	2 5/8	55	0.92

Bioflex Steam Heated Hose Assemblies. (CH Grade)



CH Hose Assembly

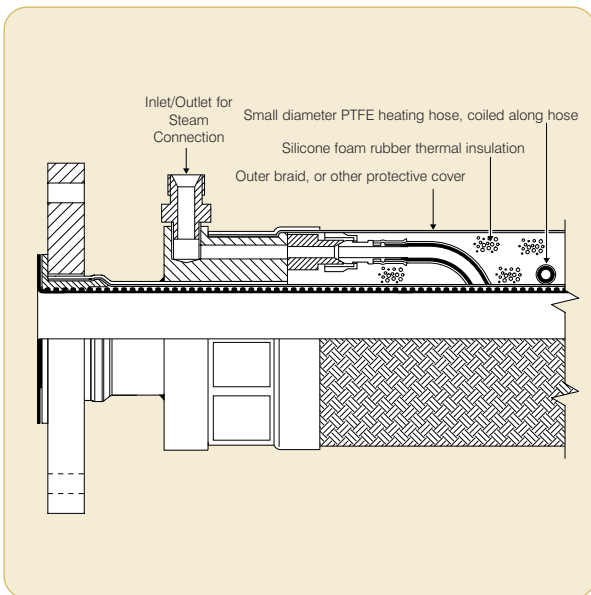

Purpose

For use in applications where the temperature of the process fluid must be maintained as it passes through the hose. This is usually required to prevent solidification or an increase in fluid viscosity. Steam heating is preferred to electrical heating in some applications for reasons of availability or safety, but is less controllable.

Description

The heating element comprises a small diameter PTFE heating hose, 6mm or 9.5mm bore size, with a single SS wire braid. This is spirally wrapped around the hose, with inlet and outlet ports attached, either both at one end or at opposite ends of the hose assembly. In the case of hose assemblies longer than 3 metres, it is usual to have several heating hoses with inlet ports at opposite ends and along the hose. This reduces the effects of temperature loss over the length of the Hose Assembly. The thermal insulation is usually closed-cell silicone foam rubber. The outer cover is a SS wire braid with a rubber cover if necessary.

Design

Each hose is custom designed and built to suit the requirements of the particular application. The following information is therefore required:

Fluid in Hose Assembly

Maintained Temperature of Fluid in Hose

Temperature of Steam or Fluid in the Heating Hose

Min/Max Ambient Temperature

Pressure/Vacuum Applied to Fluid

External Conditions of Abrasion etc

Specifications

As for Bioflex GP, SS on pages 9 and 10, except that the minimum bend radius is tripled, and the outside diameter and weight are significantly increased in line with the particular design.

Limitations

1" PTFE lined PN10 flange spigots on heated hoses can only have a maximum flare diameter of 50mm, not 63mm.

If the hose is "hanging", straight or at 90°, under its own weight, special construction is required, so advise Aflex Hose accordingly.

Minimum CH Hose Assembly Length 750mm.

Bioflex Electrically Trace Heated Hose Assemblies. (ETH Grade)

Purpose

For use in applications where the temperature of the process fluid must be maintained as it passes through the hose. In some applications, an additional 'melt out' facility may also be required.

Description

The heating element comprises either a resistance or self-regulating element spirally wrapped around the hose assembly. Resistance element heated hoses usually also require a temperature sensor to be built in to the construction. The power leads and (if applicable) temperature sensor leads emerge from the hose assembly at one end, through glands and conduits. The thermal insulation is foam rubber, silicone foam rubber for temperatures above 80°C. The outer cover may be a polypropylene yarn or SS wire braid with a rubber cover if necessary, or a ribbed PVC waterproof sleeve.

Design

Each hose is custom designed and built. Application details must be supplied by filling in an "ETH Hose Questionnaire", available from Aflex Hose. Generally, for Hazardous Areas, particularly "ZONE 1", the Self Regulating type of heating element is employed, with or without a temperature sensor and control, and flameproof glands and conduit are also required. The watts per metre of the heating element, the pitch of the spiral on the hose, and the thickness of the thermal insulation are all calculated in accordance with established formulae to give the required maintained temperature.

Specifications

As for Bioflex GP, SS on pages 9 and 10, except that the Minimum Bend Radius is tripled and the outside diameter and weight are significantly increased in line with the particular design. Maximum ETH Hose Assembly Lengths are as Bioflex GP, SS.

Limitations

1" PTFE lined PN10 flange spigots on heated hoses can only have a maximum flare diameter of 50mm, not 63mm.

If the hose is "hanging", straight or at 90°, under its own weight, special construction is required, so advise Aflex Hose accordingly.

Minimum ETH Hose Assembly Length, when collars are used 750mm.



ETH Hose Assembly

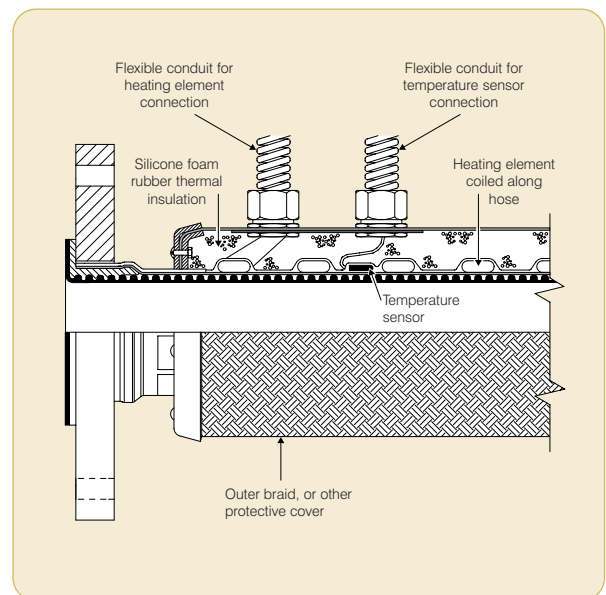

Hose Configurations & Length Calculations

Hose Configuration Requirements

Hose Assemblies are usually connected at both ends in service. They may then either remain in a fixed, or static configuration or in a flexing, or dynamic configuration.

Whether static or dynamic, the First Rule concerning the configuration of the hose is that **the bend radius of the hose must never be less than the Minimum Bend Radius (MBR) for the hose** as listed in the relevant hose brochure.

The most common situation when this is likely to occur is when the hose is flexed at the end fitting, with stress being applied to the hose at an angle to the axis of the end fitting. Typically, this happens either because the length of the hose is too short, or because the weight of the hose plus contents creates a stress at an angle to the end fitting.

The Second Rule, therefore, if possible, is to **design the configuration to ensure that any flexing in the hose takes place away from the end fittings.**

(Dynamic) Configuration

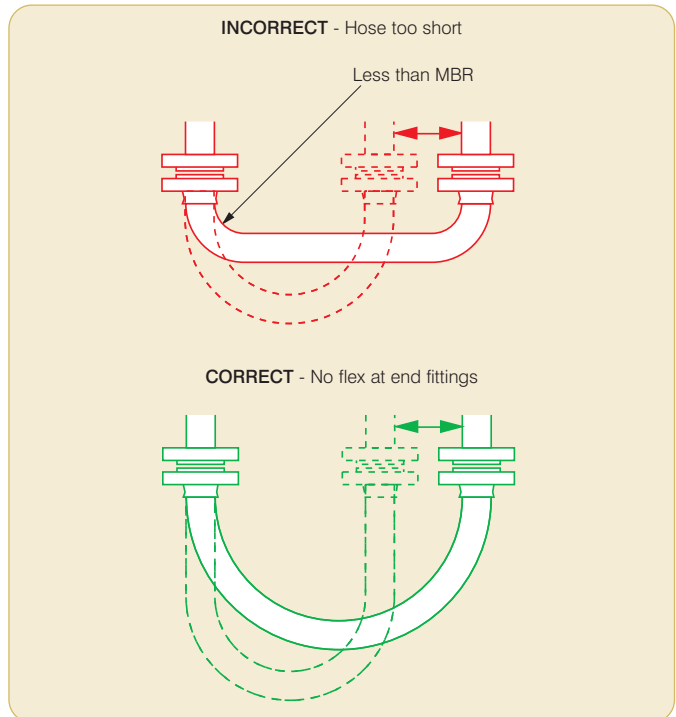

(Static) Configuration

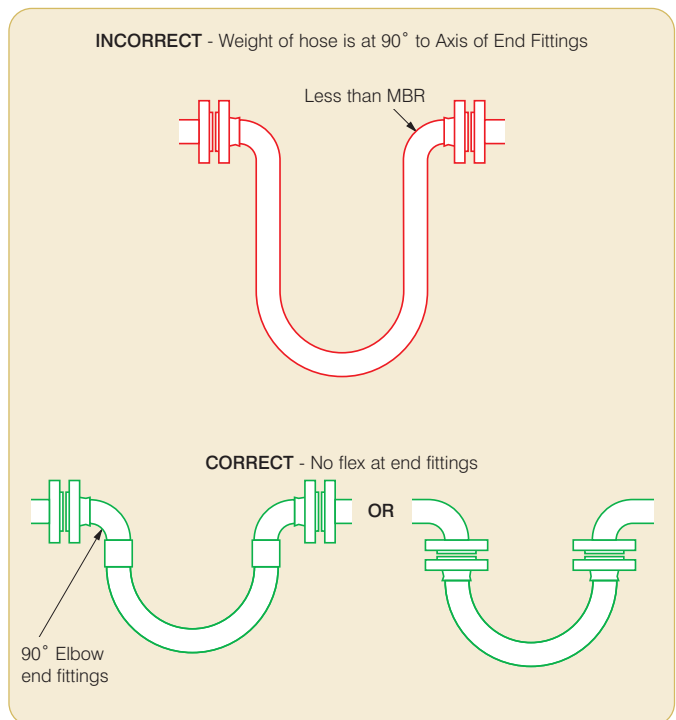

Hose Configurations & Length Calculations

The Third Rule is that **the hose configuration should always be designed, and supported where necessary, to avoid any possibility of external abrasion.**

In some cases, the length, configuration and angle of the hose can be designed to avoid abrasion. In others, static or moving support frames or support wheels are required.

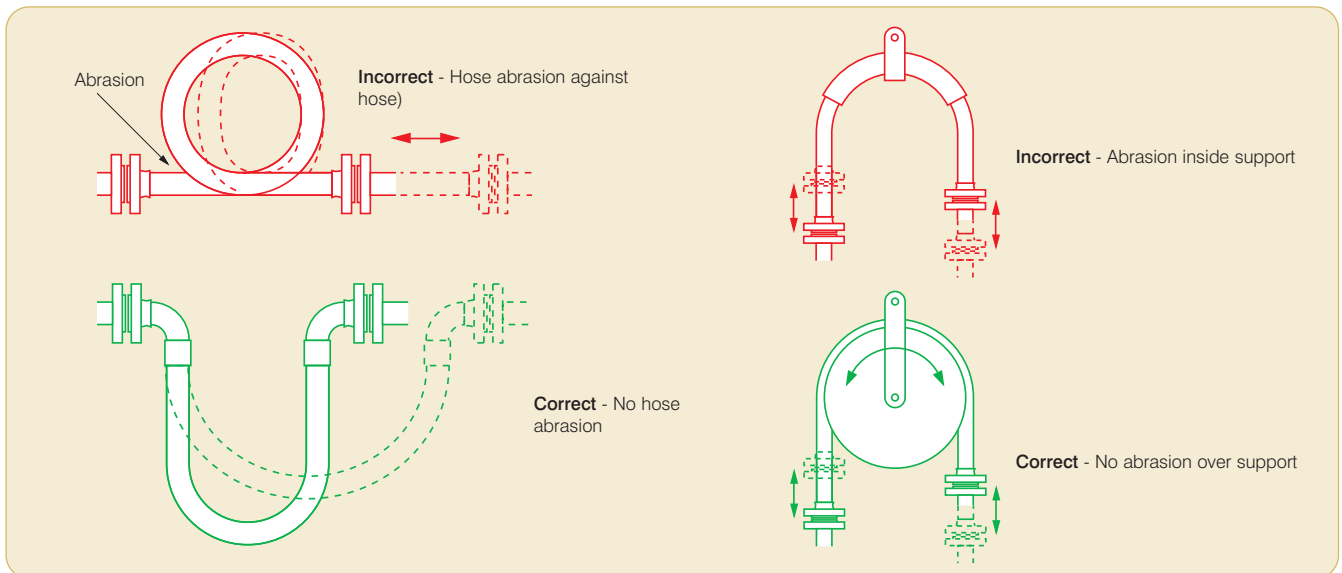

The Fourth Rule is that **the hose must not be subjected to torque, either during connection, or as a result of the flexing cycle.**

Torque (twist) in the hose can be applied during connection if the hose is accidentally twisted, or if the second end being connected is a screwed connection, and the hose is subjected to torque during final tightening.

In a flexing application, if any flexing cycle of the hose occurs in 3 dimensions instead of 2, then torque will also occur:

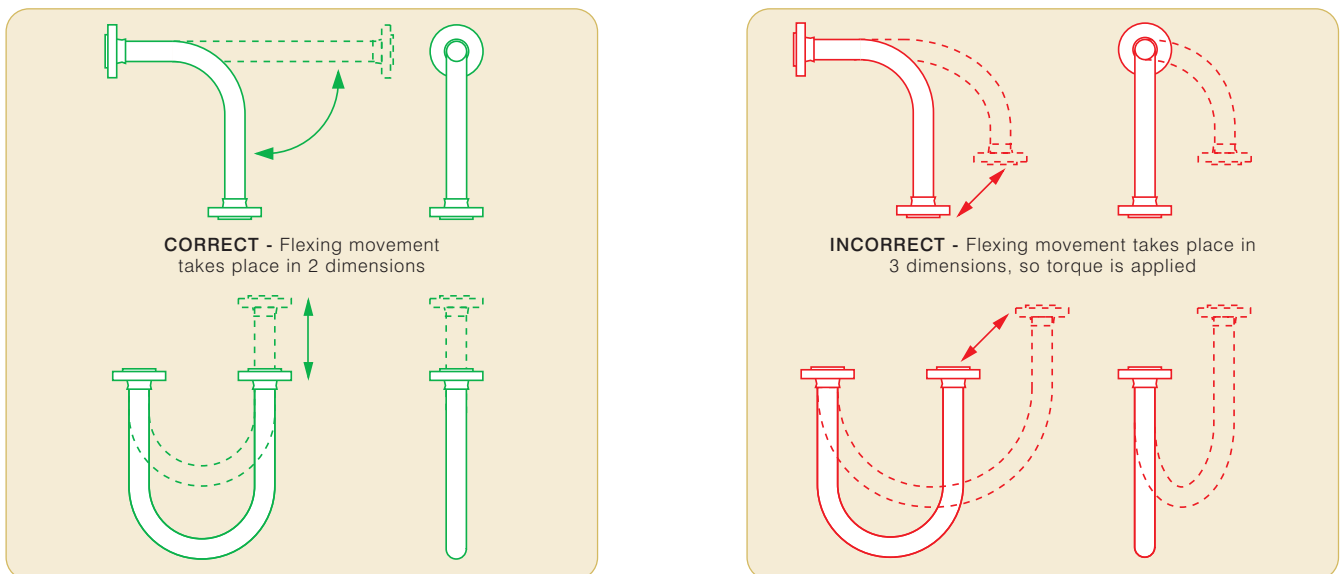

Both Corroflon and Bioflex hose have good resistance to a small level of torque, much better resistance than rubber or SS hose types, but it is still the best practice to take whatever steps are necessary to eliminate torque. If in doubt, consult Aflex Hose.

Hose Configurations & Length Calculations Continued

Calculating the Hose Length

The formula for calculating the bent section of the hose length around a radius is derived from the basic formula that the circumference of a circle = $2\pi R$, where R = the radius of the circle, and π = a constant, = 3.142.

So, if the hose goes around a 90° bend, which is $1/4$ of a full circumference, and the radius of the bend is R , then the length of the hose around the bend is = $1/4 \times 2\pi R$. Or half way round, in a U-shape, = $1/2 \times 2\pi R$.

Note :

In calculating the length of a hose assembly, the (non-flexible) length of the end fittings must be added in, also the length of any straight sections of hose, as in the following example:

Example :

To calculate the length for a 2" bore size hose with flange end fittings, to be fitted in a 90° configuration with one leg 400mm long, the other 600mm long.

$$\begin{aligned} \text{Length of Bent Section (yellow)} &= 1/4 \times 2\pi R \text{ (334)} \\ &= 1/4 \times 2 \times 3.142 \times 334 = \mathbf{525\text{mm}} \end{aligned}$$

$$\begin{aligned} \text{Length of top, Straight Section, including the top end fitting length} \\ &= 600 - 334 = \mathbf{266\text{mm}} \end{aligned}$$

$$\text{Length of bottom end fitting} = \mathbf{66\text{mm}}$$

$$\text{Total length of Hose Assembly} = 525 + 266 + 66 = \mathbf{857\text{mm}}$$

Things to consider

- A hose will normally take the longest radius available to it to go around a corner, not the MBR! Also - always remember to include the **non-flexible** end fitting lengths.
- In dynamic applications, remember to always calculate the lengths for the most extended configuration during the flexing cycle, not the least extended.
- If the configuration is simply too complex for calculation, then obtain a length of flexible tubing of some kind, mark on paper, or a wall, or floor, or both where the connection points will be relative to each other, scaled down if necessary, then manually run the flexible tubing between them with full radii round bends. Measure the extended length, then scale up if necessary to determine the approximate length of the hose.

If in doubt, consult Aflex Hose.

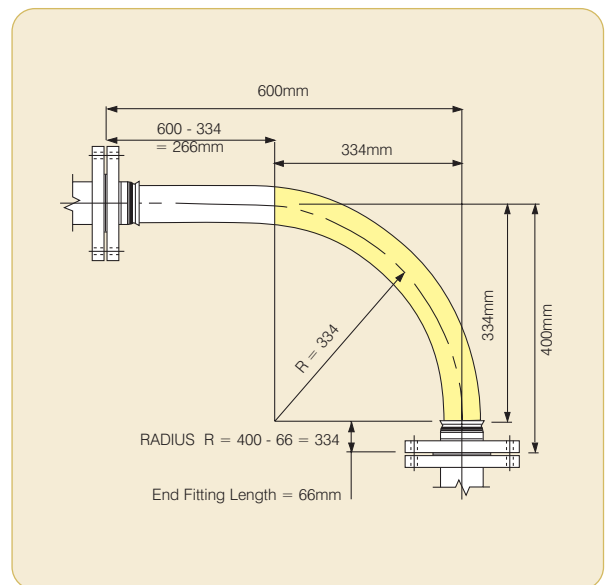
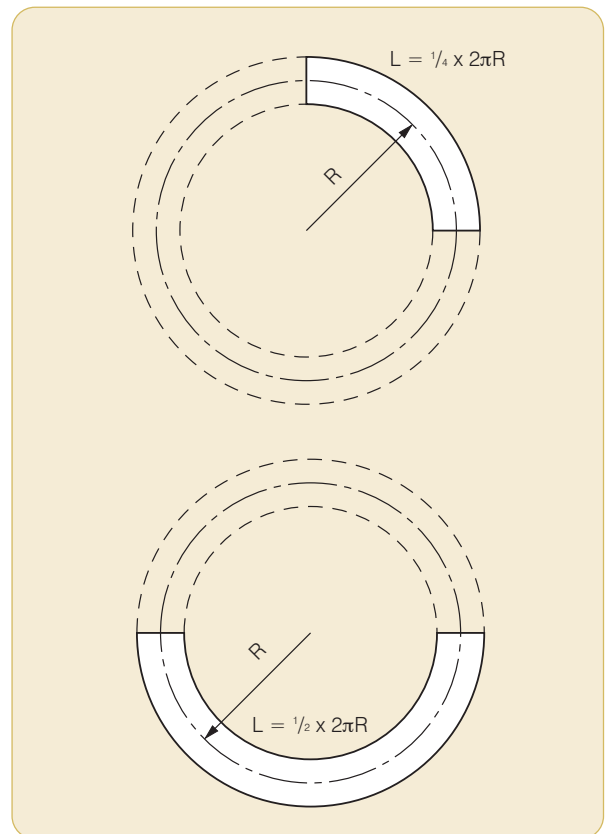

Conditions of Sale

General

Aflex PTFE hose products have not been designed or tested to be suitable for use in Aerospace or Medical Implantation applications, and such use is therefore strictly prohibited unless written approval from Aflex Hose Ltd has been given.

Similarly, PTFE hose should not be used in any radio active environment as radiation has a detrimental effect on the mechanical and electrical properties of PTFE.

Aflex Hose Ltd will not accept liability for any failures of the Aflex Hose Products which are caused by customers failing to perform their Responsibilities as specified in these Conditions of Sale.

It is the customer's strict Responsibility to review all of the usage limitations given for the hose which he intends to use in an application, to ensure that the application conditions are in compliance with those usage limitations. The usage limitations are specified both on this page, and throughout the relevant sections under "Products and Information" on the Aflex Hose website. Customers must always consult the latest, up to date information, which is available and downloadable from the Aflex website, or request from Aflex Hose Ltd.

It must be accepted, however, that the usage limitations specified elsewhere in the Hose Product Information and on this page are intended as a guide only, since every possible factor in every type of application cannot possibly be covered. It is therefore the Customer's Responsibility to ensure the design suitability and safety of the products in their intended applications, giving particular consideration to the chemical and electrostatic compatibility of the fluids or gases passing through, the possibility of diffusion of fluid or gases through the PTFE hose lining, the possibility of external corrosive conditions, the types and likelihood of excessive mechanical abuse, such as abrasion (internal or external), crushing, excessive flexing or vibrations etc, and any excessive temperature and/or pressure "pulsing" conditions, all of which may cause premature hose failure. It is also the Customer's Responsibility to consider, and take account of the degree of risk involved in any hose failure, including the provision of adequate protection in the event of any risk to employees or the general public. In applications where any type of hose failure would lead to financial losses if the hose is not replaced immediately, it is the Customer's Responsibility to order and hold in stock spare hose(s) accordingly. It is also the Customer's Responsibility to advise Aflex Hose in writing if there are any special requirements for the hose, including cleaning, or drying, or extra testing requirements which are in addition to normal industrial standards.

If the Customer has any doubts concerning these or any other usage limitation or safety parameters, it is the Customer's Responsibility to consult Aflex Hose Ltd, to request a written response to any queries.

It is the Responsibility of the Customer to ensure that if the product is sold on, or passed on, however many times, that all the necessary information including this page and the Aflex Hose website address are also passed on to the final user, together with a specific requirement that the final user must review the usage limitations in terms of his own application.

Hose Service Life

It is not possible to guarantee a minimum service life for any of the Aflex Hose products which can be applicable for every type of application.

(For example, PTFE lined hose has been used in one application where it was cycled with hot steam, then cold water, also flexed every 17 seconds 24 hours per day, and the customer was very satisfied with a service life of 3 weeks before failure. In other light duty applications carrying pharmaceutical products, however, many Corroflon hoses are still performing satisfactorily after 20 years in service).

Service life predictions or guarantees can only be given in cases where all the relevant information concerning the application is given in writing to Aflex Hose, and Aflex Hose subsequently replies in writing prior to the order being placed.

If such a written undertaking is not sought and given, then Aflex Hose cannot be held liable for any hose product failure which the customer considers to be premature, excepting failures which are due to faulty materials or manufacturing defects.

24 Month Warranty

Aflex Hose Ltd warrants its products to be free from faulty materials or manufacturing defects from the date of the initial sale, for 24 months.

Product Failure

In the event of a product failure, Aflex Hose requests that the product should not be cut up or tampered with, but should be de-contaminated and returned to Aflex Hose, plus a decontamination certificate, for examination and analysis of the fault. The customer should also provide full details in writing of the application conditions under which the hose failed, including Pressure, Vacuum, Temperature, Flexing and any cycling of any of these, also the fluid and gases passing through the hose, and the total time that the hose has been in service. The customer may send his own witness to the examination if required. Aflex Hose will provide a full Non Conformance Report for the customer.

If faulty materials or a manufacturing defect in the hose was responsible for the failure to perform then, the maximum liability to be accepted by Aflex Hose would include the invoice value of the failed hose itself, or the invoice value of the whole customer order if appropriate, also any reasonable costs for removal and replacement of the hose, and costs for packing and despatching the failed hose back to Aflex Hose. Aflex Hose Ltd will not accept liability for any other consequential or financial losses, including, but not limited to loss of profits, loss of products or downtime costs.

Untested Hose for Self Assembly by Customers

Aflex Hose sometimes supplies "loose" hose, without end fittings attached to Self Assembly Customers, who will then cut the hose to length and attach end fittings to make up Hose Assemblies.

Self Assembly Customers must then accept the responsibility to carry out pressure testing of 100% of such assemblies to 1/2 times the Maximum Working Pressure before supply for end use, to validate both the hose and the end fitting attachment.

Unless the customer requests, and Aflex Hose confirm that their loose hose is pressure tested before supply, such testing is not normally applied by Aflex Hose, because this testing requirement is satisfied by the Self Assembly Customer during his own testing of the finished Hose Assembly.

The Self Assembly Customer must also accept responsibility for determining and approving the Design Suitability of the hose assemblies for their intended use before supply.

This includes determining and requesting or applying any special tests which may be identified as necessary to ensure suitability for the intended use.

Aflex Hose will only accept liability for its hose products which are assembled by customers themselves if all the hose and fitting components were either supplied by Aflex Hose or manufactured in accordance with Aflex Hose drawings, and they were assembled and tested in accordance with Aflex Hose's current Manufacturing and Testing Instructions.

Untested Hose Assemblies

Aflex Hose is sometimes requested by customers to attach non-standard end fittings to hose assemblies which they supply, and in some cases it is not possible to connect these fittings to the pressure test system. In such cases a Concession not to test is obtained from the Customer, and a label is attached to the hose assembly, warning that it requires pressure testing before use.

Force Majeure

Aflex Hose Ltd shall not be liable for any delay or default in performing in accordance with any Customers' order if the delay or default is caused by conditions beyond its control, including, but not limited to wars, insurrections, strikes, natural disasters or performance failures by Carriers, sub-contractors or other third parties outside the control of Aflex Hose Ltd.

Legal System

These Conditions of Sale are subject to English Law.

AFLEX COMPANIES AND DISTRIBUTORS WORLDWIDE

BELGIUM

PMA - Heleon NV
Bredabaan 881, 2170 Merksem, Antwerpen, Belgium
Telephone: (+32) 364 142 33 Fax: (+32) 364 142 34
Email: info@pma-heleon.be Web Site: www.pma-heleon.be

GERMANY & AUSTRIA

Tecnoplast GmbH
Postfach 11 12 31, 40512 Dusseldorf, Germany
Telephone: (+49) 211 537 433-0 Fax: (+49) 211 593 914
Email: info@tecnoplast.de Web Site: www.tecnoplast.de

HUNGARY

Szalai & Tarsa KFT
Angst + Pfister Kepviselet
H-1106 Budapest, Maglodi UT 16, Hungary
Telephone: (+36) 126 166 69 Fax: (+36) 126 026 07
Email: szalaig@axelero.hu Web Site: www.szalaikft.hu

HOLLAND & BELGIUM

Imbema Cleton
PO Box 54, 3130 AB, Vlaardingen, Netherlands
Telephone: (+31) 104 345 922 Fax: (+31) 104 601 904
Email: info@imbemacleton.nl Web Site: www.imbemacleton.nl

IRELAND

Dublin Engineering
184 Lower Kimmage Road, Dublin 6, Ireland
Telephone: (+353) 149 081 49 Fax: (+353) 149 083 11
Email: dublinengineering@eircom.net

ISRAEL

Transtecnica
Hytzer St. 18, Industrial Zone Holon, P.O.B. 1703,
Holon, 58117, Israel
Telephone: (+972) 3 5599522 Fax: (+972) 3 5599544
Web Site: www.transtecnica.com

JAPAN & CHINA

Tofle Co. Inc.
Toyoda Nissei Kitahama Bldg No -10, 1-Chome, Kouraibashi,
Chuo-Ku, Osaka, 541-0043, Japan
Telephone: (+81) 647 065 000 Fax: (+81) 647 065 001
Email: international@tofle.com Web Site: www.tofle.com

POLAND, CZECH REPUBLIC & SLOVAKIA

Tubes International SP Z.O.O.
Ul. Bystra 15A, 61 - 366 Poznan, Poland
Telephone: (+48) 616 530 222 Fax: (+48) 616 530 220
Email: import@tubes.com.pl Web Site: www.tubes.com.pl

SINGAPORE & INDONESIA

Metallic Engineering (F.E.) Pte Ltd
No. 8 Loyang Walk
Loyang Industrial Estate, 508791, Singapore
Telephone: (+65) 654 623 95/654 623 96 Fax: (+65) 654 684 49
Email: metallic@singnet.com.sg Web Site: www.metallic.com.sg

SPAIN & PORTUGAL

Comercial Gasso S.A.
Pol. Ind. Can Calderon, C/Murcia 35, Nave C, 08830 Sant Boi De
Llobregat, Barcelona, Spain
Telephone: (+34) 936 529 800 Fax: (+34) 936 529 804
Email: gasso@gasso.com Web Site: www.gasso.com

SCANDINAVIA

Euroflon A.B.
Box 2045, S-591 02 Motala, Sweden
Telephone: (+46) 141 234 430 Fax: (+46) 141 513 13
Email: info@euroflon.se Web Site: www.euroflon.se

SWITZERLAND

Flextechnik - M. Hauri
Heidenlochstrasse 56, CH-4410, Liestal, Switzerland
Telephone: (+41) 61 923 05 38 Fax: (+41) 61 923 05 39
Email: flextechnik@tiscalinet.ch

USA

Afex Hose USA, L.L.C.
6111 Keller's Church Road, Unit B, Pipersville,
Bucks County, Pennsylvania, PA 18947, United States of America
Telephone: (+1) 215 766 1455 Fax: (+1) 215 766 1688
Web Site: www.aflex-hose.com

The World's Leading Manufacturer of PTFE Flexible Hose.

Spring Bank Industrial Estate, Watson Mill Lane,
Sowerby Bridge, Halifax, West Yorkshire HX6 3BW
Website: www.aflex-hose.com



Certificate No. 1977

BIOFX/28.02.08